

General characteristics

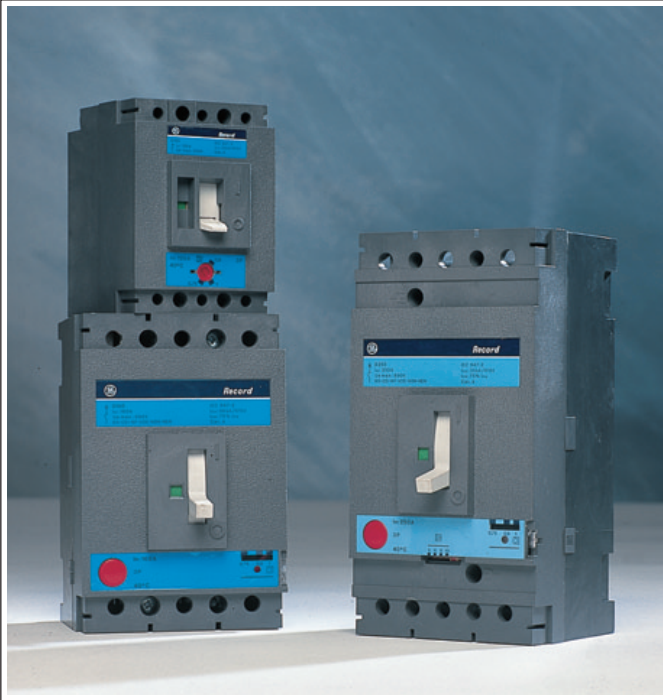

Use

The Record circuit breakers are suitable for three levels of performances:

- normal breaking capacity, type D,
- high breaking capacity, type DH,
- limiter circuit breaker, type D ... L.

By adding or replacing elements, it is possible to perform the following functions:

- earth leakage protection,
- visible isolation,
- low magnetic threshold protection,
- instantaneous protection alone
- selectivity of protection.

As a variant:

- source changeover switches for replacement source,
- switches for controlling and isolating circuits.

Breaking capacity (according to IEC 947-2 at 415V)

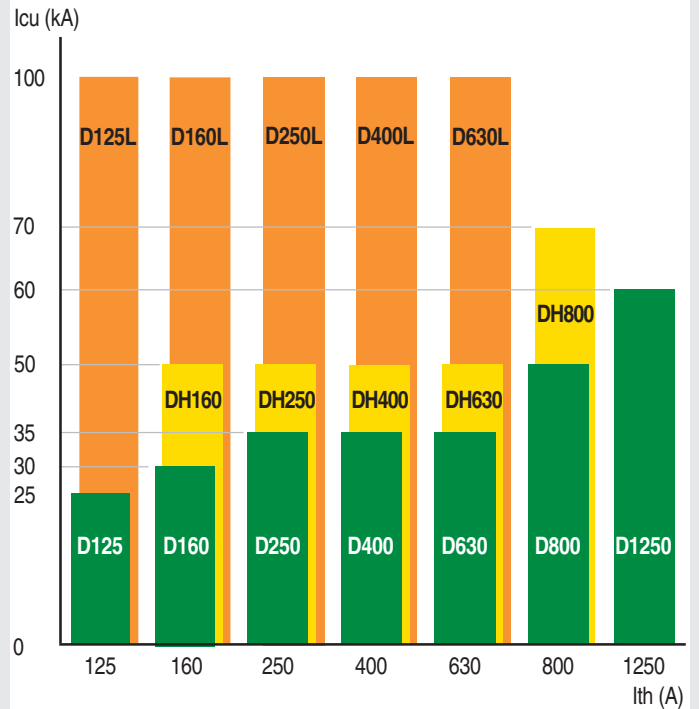

Description

Within an isolating box, the Record circuit breaker contains:

- 2 (D125), 3 or 4 poles,
 - A mechanism enabling fully visible isolation. The control handle can only display "OFF" if all the contacts are actually open and separated by a distance greater than:
 - 9 mm for D125
 - 15 mm for D160, D250
 - 20 mm for D400, D630, D800, D1250,
 - A display showing the exact position of contacts
 - red: contacts closed
 - white: contacts open, unit tripped
 - green: contacts open, fully visible isolation,
 - 1 release unit:
 - integrated for D125, D160, D250
 - interchangeable for D400, D630, D800, D1250
- containing:
- a trip push-button
 - compensated thermal elements for - 5°C to + 40°C adjustable from:
 - 0.75 to 1 for D125, D160, D250
 - 0.8 to 1 for D400, D630, D800, D1250
 - Adjustable magnetic releases (fixed for D125)



Structure

Record circuit breakers are available as:

- fixed unit, front or rear connections,
- withdrawable unit with front or rear connections.

The withdrawable version contains:

- a monoblock fixed isolating part, protection level IP 2X,
- a safety system at withdrawal,
- An upline-downline error prevention device,
- optional: rating error prevention device, wiring isolation.

The Record D800 and D1250 withdrawable devices have a fixed part with plug-in and withdrawal control by crank and optional isolation shutter and position indicator.

Versions:

- standard thermal magnetic
- low threshold type A thermal magnetic
- instantaneous type B magnetic only
- fixed, selective thermal magnetic type SM or S releases, magnetic
- for direct current.

Option of lead sealing access (front panel) to settings.

Auxiliaries, accessories

Record circuit breakers can receive:

- auxiliaries:
 - display contacts (ON-OFF, fault)
 - voltmeter releases (ST shunt, UV undervoltage)
- installation and connection accessories:
 - terminals, terminal covers,
 - padlocks or locks.

Installation

Record circuit breakers Record can be mounted in all industrial or tertiary installations.

Adapter accessories such as plates or racks have been designed for integration into our Modula 400 boxes and Modula 4000 housings

Power

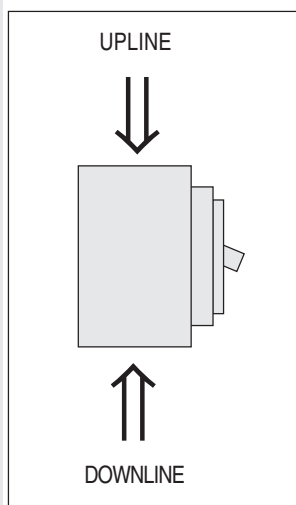

		D125	D160	D250	D400	D630	D800	D1250
220/240V	Upline	•	•	•	•	•	•	•
	Downline	•	•	•	•	•	•	•
380/415V	Upline	•	•	•	•	•	•	•
	Downline	•	•	•	•	•	•	•
500V	Upline	•	•	•	•	•	•	•
	Downline	•	-	-	•	•	•	•
660/690V	Upline	-	•	•	•	•	•	•
	Downline	-	-	-	•	•	•	•

Mounting

The mounting of a fixed circuit breaker can be:

vertical

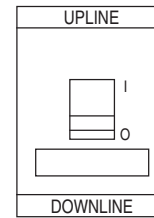

horizontal

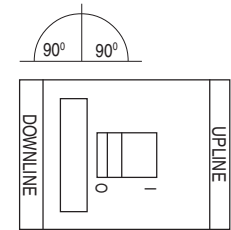

Circuit breaker type:

Fixed 125 / 1250	•	•
Withdrawable 125 / 630	•	•
Withdrawable type V 160 /1250	•	•

Safety perimeter

During breaking, all circuit breakers produce external agents (fragments, gases, . . .); in order to guarantee security during this phase, it is necessary to respect the safety distances indicated below:

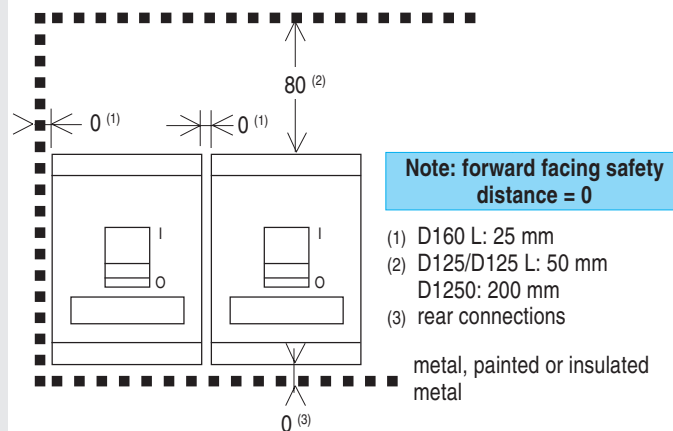

Environmental endurance

Record circuit breakers and their additional units, meet the implementation requirement II of the standard NF C 63-100:

- relative humidity: 80% to 55° C and 95% to 45° C. (hot and humid climate).

Accreditation/certification

IEC 947-2
BS, CEI, NBN, NF C, VDE
ASEFA - Bureau Véritas - Germanischer Lloyd -
Lloyd's Register of Shipping - RINA

Circuit breaker characteristics: page A.4
Release characteristics: page A.6
Auxiliaries and accessories: page A.8



Technical data of thermal magnetic releases

Circuit breakers		D125	D160	D250												
Releases		integrated	integrated	integrated												
Type standard	thermal adjusted for - 5°C to + 40°C	adjustable from 0.75 to 1 lth			adjustable: 0.75 to 1 lth			adjustable: 0.75 to 1 lth								
		rat.	N (1)	40°C	50°C	60°C	rat.	N (1)	40°C	50°C	60°C	rat.	N (1)	40°C	50°C	60°C
		16	-	16	15	14.5	25	-	25	23.5	22.5	100	63	100	95	90
		25	-	25	23.5	22.5	40	25	40	38	36	125	63	125	118.5	112.5
		40	25	40	35	36	63	40	63	59.5	56.5	160	100	160	152	144
		63	40	63	60	57	100	63	100	95	90	200	100	200	190	180
		80	40	80	76	72	125	63	125	118.5	112.5	250	125	250	237.5	225
		100	63	100	95	90	160	100	160	152	144					
		125	63	125	118	112										
				D125L fixed, D125M withdrawable					D250L fixed, D250M fixed, D250 withd.							
		100	63	95	90	85	200	100	200	190	180	250	125	230	215	205
		D125L withdrawable					D250L withd., D250M withd.									
		100	63	90	85	80	200	100	180	170	160	250	100	205	195	185
		125	63	110	100	90										
	magnetic	fixed					adjustable					adjustable				
		operating threshold (A)					adjustment range (A)					adjustment range (A)				
		rat.	I _{rm}				rat.	min.	max.			rat.	min.	max.		
		16	200				25	250	300			100	500	1200		
		25	300				40	320	480			125	625	1500		
		40	480				63	440	750			160	800	1900		
		63	750				100	600	1200			200	1000	2400		
		80	1000				125	750	1500			250	1250	2500		
		100	1200				160	800	1900							
		125	1200													
Type A low threshold instantaneous operation	thermal magnetic	identical to standard type					identical to standard type					identical to standard type				
		fixed					adjustable					adjustable				
		operating threshold (A)					adjustment range (A)					adjustment range (A)				
		rat.	I _{rm}				rat.	min.	max.			rat.	min.	max.		
		25	90				125	300	500			200	375	750		
		40	130				160	375	625			250	625	1500		
		63	260													
		80	400													
		100	400													
		125	400													
Type B instantaneous operation only	thermal magnetic	none					none					none				
		fixed					adjustable					adjustable				
		operating threshold (A)					adjustment range (A)					adjustment range (A)				
		rat.	I _{rm}				rat.	min.	max.			rat.	min.	max.		
		16	200				63	440	750			200	1000	2400		
		25	300				100	600	1200			250	1250	2500		
		40	480				125	750	1500							
		63	750				160	800	1900							
		80	1000													
		100	1200													
125	1200															
Type SM or S selective operation	thermal magnetic	identical to standard type					identical to standard type					identical to standard type				
		fixed					fixed					fixed				
		operating threshold (A)					operating threshold (A)					operating threshold (A)				
		rat.	I _{rm}				rat.	I _{rm}				rat.	I _{rm}			
		100	2000				160	2500				160	2500			
		125	2000				200	2500				200	2500			
					160	2000				250	2500					
Type C instantaneous operation only for direct current																

(1) Reduced neutral
(2) No thermal operation for direct current



D400					D630					D800					D1250				
interchangeable					interchangeable					interchangeable					interchangeable				
adjustable: 0.8 to 1 lth					adjustable: 0.8 to 1 lth					adjustable: 0.8 to 1 lth					adjustable: 0.8 to 1 lth				
rat.	N (2)	40°C	50°C	60°C	rat.	N (1)	40°C	50°C	60°C	rat.	N (1)	40°C	50°C	60°C	rat.	N (1)	40°C	50°C	60°C
250	125	250	237	225	400	200	400	370	340	630 ⁽²⁾	320	630	580	535	800 ⁽²⁾	400	800	760	675
320	160	320	304	288	500	250	500	460	425	800 ⁽²⁾	400	800	760	720	1000 ⁽²⁾	500	1000	950	850
400	200	400	380	360	630 ⁽²⁾	320	630	580	535						1250 ⁽²⁾	630	1250	1150	1050
D400 withdrawable					D630 withdrawable					D800 withdrawable									
400	200	370	340	310	500	250	460	425	390	630 ⁽²⁾	320	600	550	505					
					630 ⁽²⁾	320	580	535	495	800 ⁽²⁾	400	720	675	635					
adjustable					adjustable					adjustable					adjustable				
adjustment range (A)					adjustment range (A)					adjustment range (A)					adjustment range (A)				
rat.	min.	max.			rat.	min.	max.			rat.	min.	max.			rat.	min.	max.		
250	1500	3000			400	2000	4000			630	3150	5000			800	4000	8000		
320	1900	3850			500	2500	5000			800	4000	6400			1000	5000	10000		
400	2000	4800			630	3150	5000								1250	6250	12500		
identical to standard type					identical to standard type					identical to standard type					identical to standard type				
adjustable					adjustable					adjustable					adjustable				
adjustment range (A)					adjustment range (A)					adjustment range (A)					adjustment range (A)				
rat.	min.	max.			rat.	min.	max.			rat.	min.	max.			rat.	min.	max.		
320	750	1200			500	1000	2000			630 (2)	1250	2500			1000 (2)	2400	4000		
400	960	1700			630 (2)	1250	2500			800 (2)	2000	3000			1250 (2)	3000	5000		
none					none					none					none				
adjustable					adjustable					adjustable					adjustable				
adjustment range (A)					adjustment range (A)					adjustment range (A)					adjustment range (A)				
rat.	min.	max.			rat.	min.	max.			rat.	min.	max.			rat.	min.	max.		
320	1900	3850			500	2500	5000			630	3150	5000			1000	5000	10000		
400	2000	4800			630	3150	5000			800	4000	6400			1250	6250	12500		
identical to standard type					identical to standard type					identical to standard type					identical to standard type				
fixed					fixed					fixed					adjustable				
operating threshold (A)					operating threshold (A)					operating threshold (A)					adjustment range (A)				
rat.	I _{rm}				rat.	I _{rm}				rat.	I _{rm}				rat.	min.	max.		
250	3000				400	4000				630	5000				800	4000	8000		
320	3850				500	5000				800	6400				1000	5000	10000		
400	4800				630	5000									1250	6250	12500		
															adjustment range (A)				
															min. max.				
															3000 6000				



Functions

Circuit breakers

Earth leakage	
By isolation visible breaking	
Switch	standard differential visible breaking
Automatic or manual source changeovers	

Electrical auxiliaries

Auxiliary "ON-OFF" switch	AS
Bell alarm	BA
Voltmetric shunt release	ST
Undervoltage release	UV

Control accessories

Manual rotary control
Electrical control

Safety accessories

Terminal covers	
Locks	padlock key lock
Isolating shutter	
Rating error prevention	

Installation/Connection

Fixed unit	front connections	FAV
	rear connections	FAR
Withdrawable unit	front connections	DAV
	rear connections	DAR

D125	D125L	D160	DH160	D160L	D250	DH250	D250L
D125M	D125LM	D160M	DH160M	-	D250M	DH250M	-
-	-	D160VE D160MVE D160V	DH160VE DH160MVE DH160V	D160LVE	D250VE D250MVE D250V	DH250VE D250MVE D250V	D250LVE
J125	-	J160	-	-	J250	-	-
J125M	-	J160M	-	-	J250M	-	-
-	-	J160VE J160MVE J160V	-	-	J250VE J250MVE J250V	-	-
-	-	•	•	•	•	•	•
•	•	•	•	•	•	•	•
•	•	•	•	•	•	•	•
•	•	•	•	•	•	•	•
•	•	•	•	•	•	•	•
•	•	•	•	•	•	•	•
•	•	•	•	•	•	•	•
•	•	•	•	•	•	•	•
•	•	•	•	•	•	•	•
•	•	•	•	•	•	•	•
•	•	•	•	•	•	•	•
•	•	•	•	•	•	•	•

(1) Earth leakage protection can be achieved with a separate core unit (SHR or MTS)
 (2) Terminal covers 4P only.



Operating curves

D125 - 16 and 25A

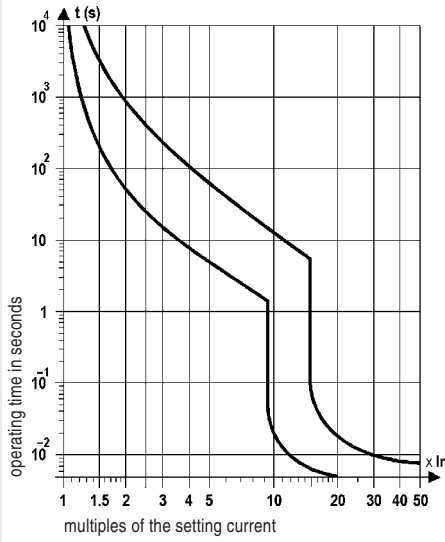

D125 - type A, 25A

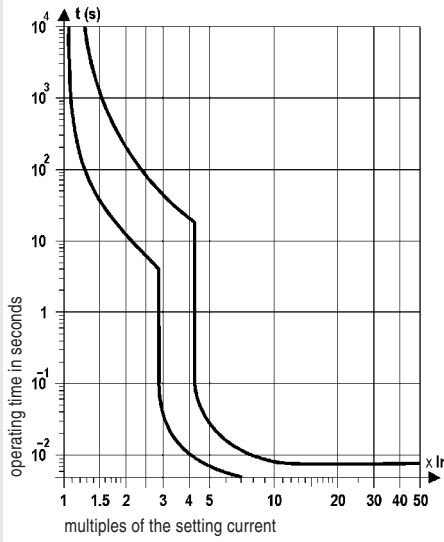

D125 - type A, 40 and 125A

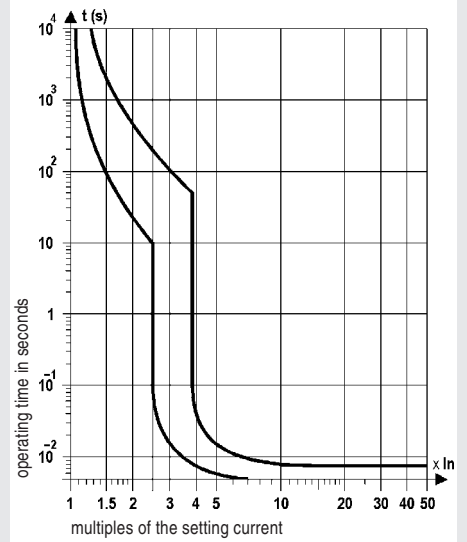

D125 - 40 to 100A

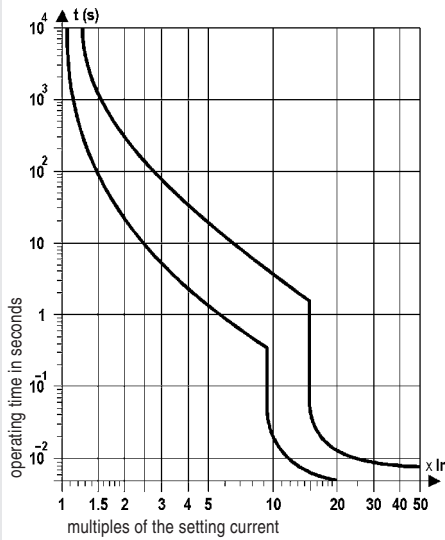

D125 - type A, 80A

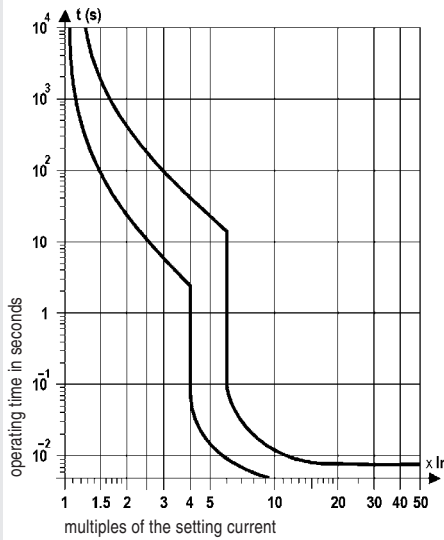

D125 - 125A

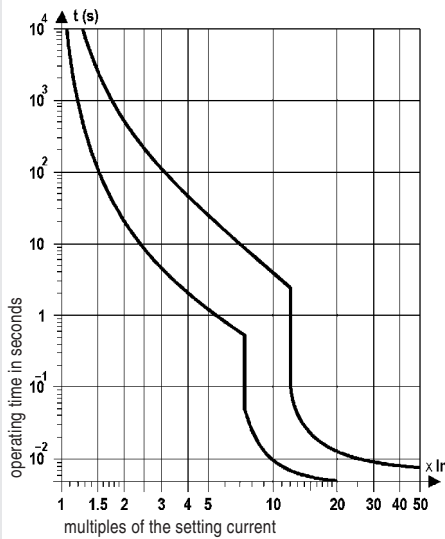

D125 - type A, 63 and 100A

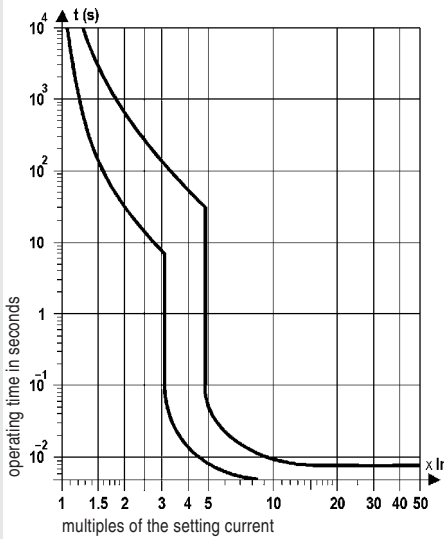



Operating curves

D160

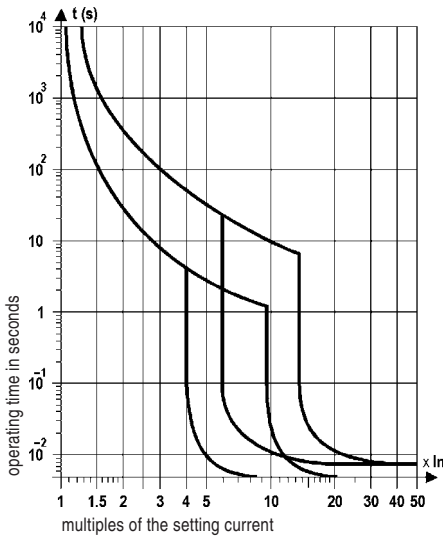

D250

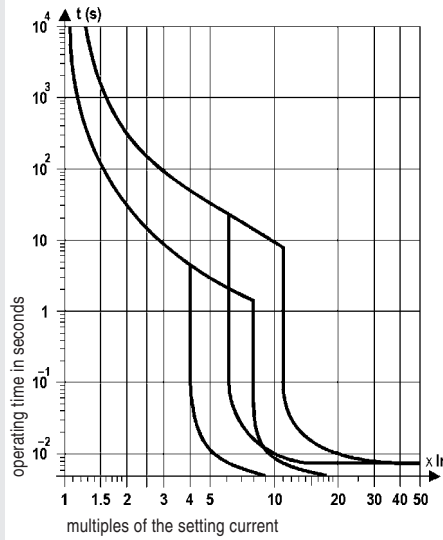

D400

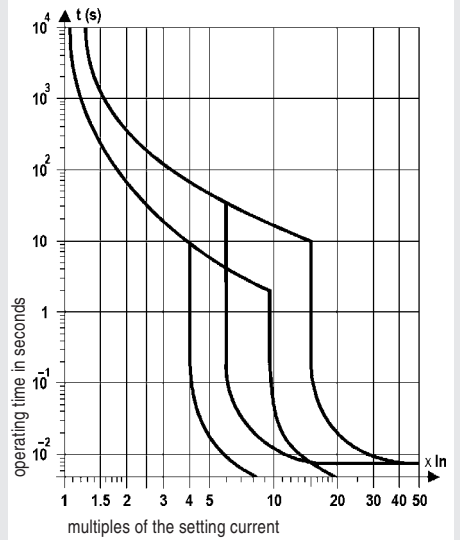

D160 - type A

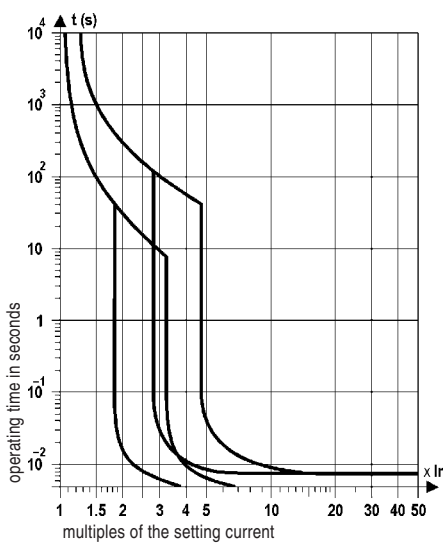

D250 - type A, 200A

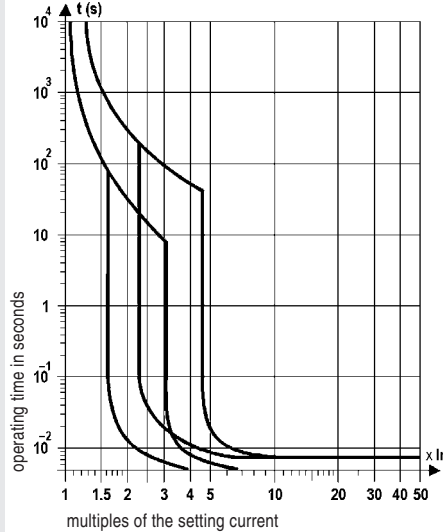

D400 - type A, 320/400A

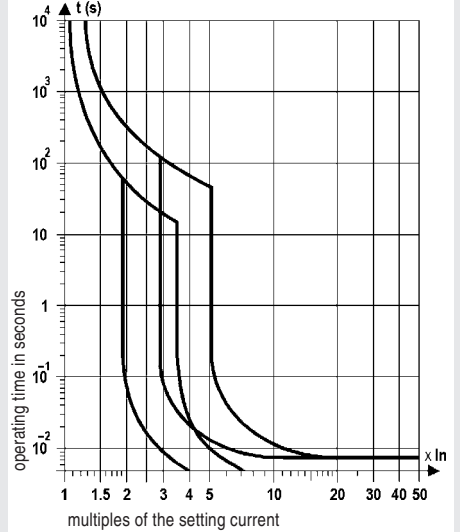

D250 - type A, 250A

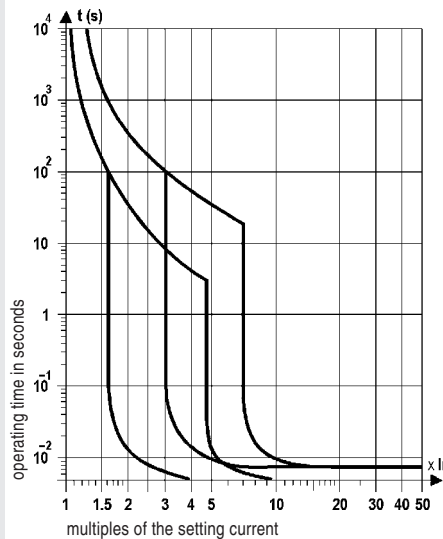



Operating curves

D630 - 400/500A

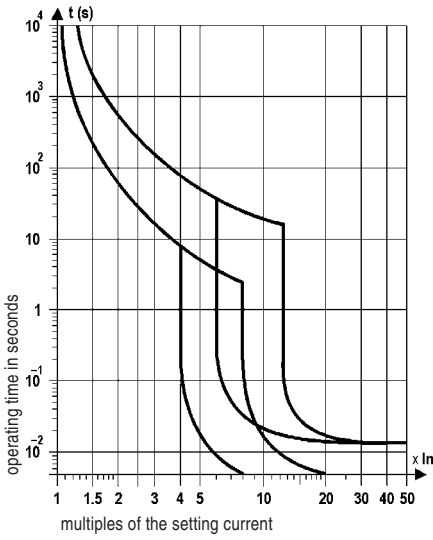

D800 - 630/800A

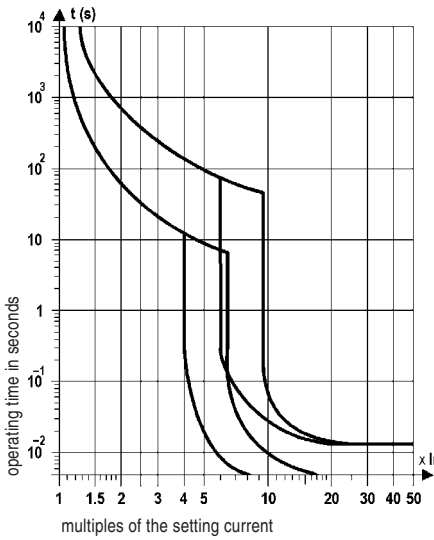

D1250 - 1000/1250A

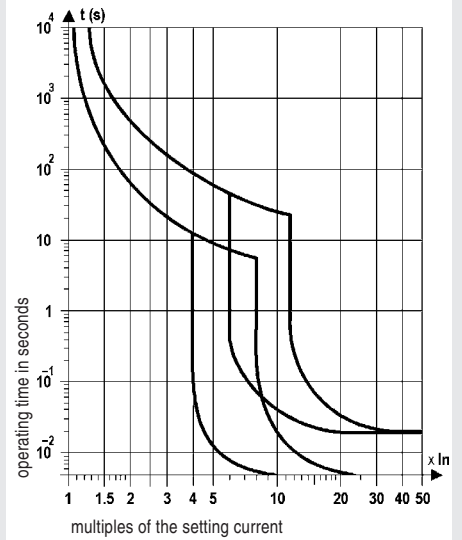

D630 - 630A

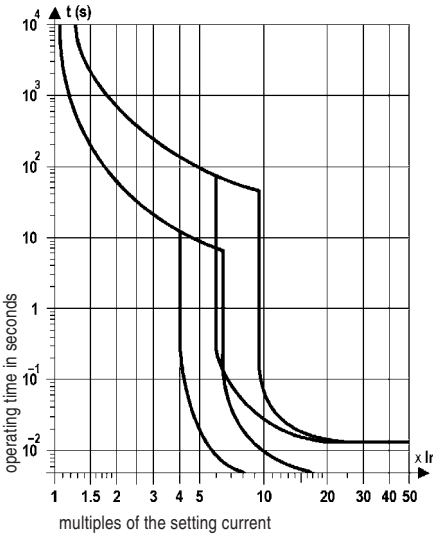

D800 - type A, 630/800A

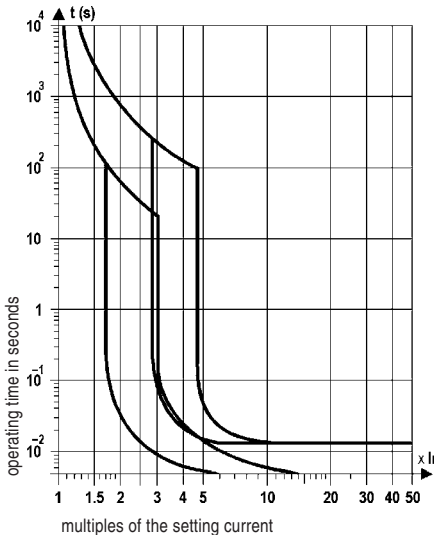

D1250 - type A, 1000/1250A

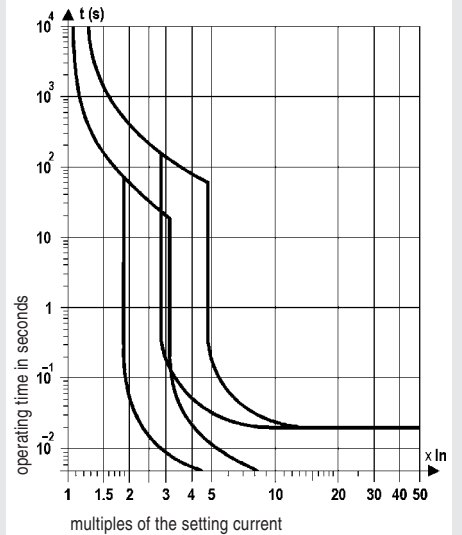

D630 - type A, 500/630A

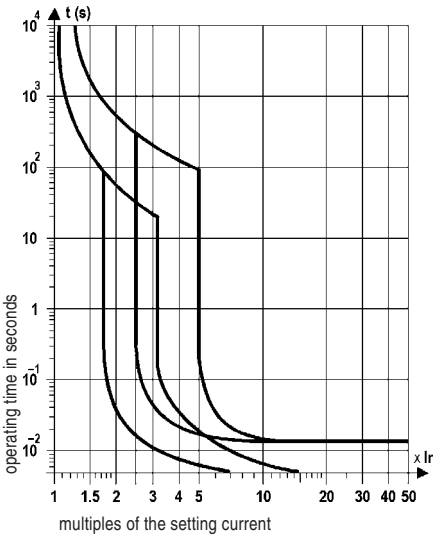



Limiter circuit breakers

General

The limiting capacity of a circuit breaker is the expression of the breaker's capacity, in the event of a short-circuit, to let no current through that is greater than the assumed fault current.

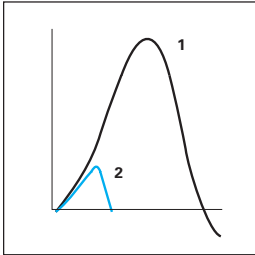

- 1: I_{cc} peak assumed
- 2: I_{cc} peak limited

This characteristic is expressed by limitation curves

D125 L, D160 L, D250 L

The limitation function is performed by a unit which is adapted on site, to the upper part of standard or earth leakage protection circuit breakers.

The housing contains:

- a special contacts device allowing a breaking capacity without circuit breaking, of 100 kA (under 415V)
- a front facing short-circuit counter



Short-circuit current limitation curves, 380/415 V

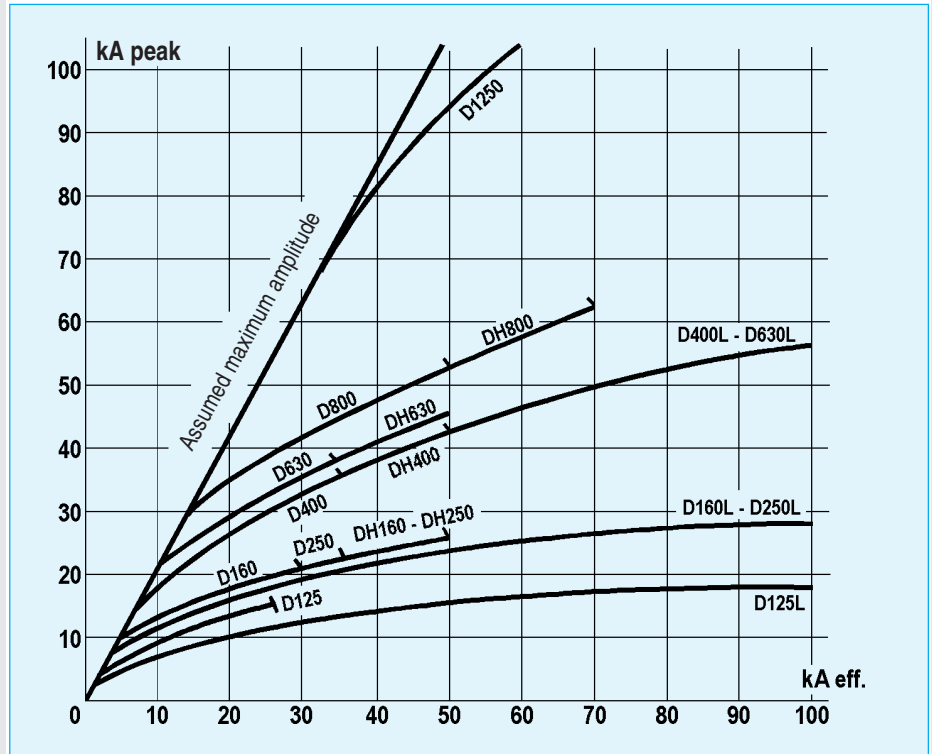

Thermal constraint limiting curves

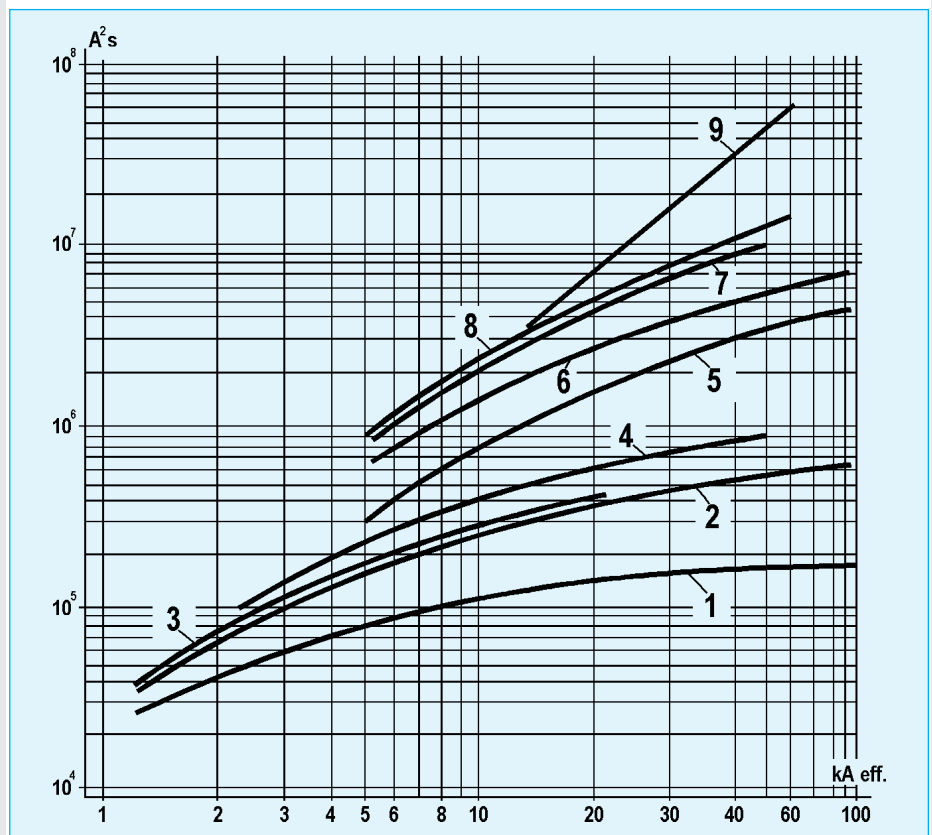

- | | |
|--------------------------|-----------------|
| 1. D125 L | 6. D630 L |
| 2. D160 L - D250 L | 7. D630 - DH630 |
| 3. D125 - D250 - DH250 | 8. D800 - DH800 |
| 4. D160 - DH160 | 9. D1250 |
| 5. D400 - DH400 - D400 L | |

Switches J

A
14



Type	
Rated thermal current Ith	(A)
Short term withstand current Icw	(kA eff.) time (s)
Rated short-term making capacity Icm	(kA peak)
Number of poles	
Suitability for isolation (visible breaking indication)	
Variants	
Ground leakage By isolation visible breaking	
Source changeover automatic or manual	
Auxiliaries	
	switches (2) type
Display contact "ON-OFF"	AS
Bell alarm (3)	BA
Shunt release	ST
Undervoltage release	UV
Controls	
Manual rotary	
Electric	
Accessories	
Connection accessories	
Terminal covers	
Locks	padlock key lock
Isolating shutter	
Installation/connection	
Fixed Unit	front connections FAV rear connections FAR
Withdrawable unit	front connections DAV rear connections DAR

Record switches are derived from Record circuit breakers. They can receive auxiliaries, controls, and the circuit breaker accessories from which they come.

J125*	J160	J250	J400	J630	J800	J1250		
100/125	160	250	400	630	800	1250		
1.2	2	2.5	4	5.5	7	16		
2	4	3	10	13	10	8		
1.7	3.5	4	9	9	14	32		
2-3-4	3-4	3-4	3-4	3-4	3-4	3-4		
•	•	•	•	•	•	•		
J125M	J160M	J250M	J400M	J630M	(1)	(1)		
-	J160VE	J250VE	J400VE	J630VE	J800V	J1250V		
J160MVE	J250MVE	J400VR	J630VR	J630V				
-	J160V	J250V	J400V	J630V				
	•	•	•	•	•	•		
			T	V	T	V	T	V
•	•	•	•	•	•	•	•	•
•	•	•	-	-	-	-	•	-
•	•	•	•	-	•	-	•	-
•	•	•	•	-	•	-	•	-
•	•	•	•	•	•	•	•	•
•	•	•	•	• (4)	-	-	•	•
•	•	•	•	•	•	•	•	•
•	•	•	•	•	•	•	•	•
-	-	-	-	-	•	•	•	•
•	•	•	•	•	•	•	•	•
•	•	•	•	•	•	•	•	•
•	•	•	•	•	•	•	•	•
•	•	•	•	•	•	•	•	•

* rating 100 and 125A

- (1) Ground leakage protection can be achieved with separate magnetic core units (see page A.15)
 (2) T: switch type "All auxiliaries"
 V: switch type "Lock"
 (no safety system at withdrawal)
 (3) ST or UV release
 (4) terminal cover 4P only



Earth leakage protection circuit breakers

Earth leakage protection

Earth leakage circuit breakers give protection in case of:

- isolation fault (decree of 14/11/1988)
- overload and short-circuit

They consist of:

- a Record circuit breaker
- a voltmetric shunt release installed in the circuit breaker
- an earth leakage protection device including magnetic core and an electronic unit with integrated power supply:
 - device built into D125 circuit breakers,
 - site adaptable device for circuit breakers D160, D250, D400, D630,
 - remote control AC/DC 220/415V

Characteristics

	D125 M D125 LM	D160 MD250 M DH160 M-DH250 M D160 LM-D250 LM	D400 M-D630 M DH400 M-DH630 M D400 LM-D630 LM
Nominal voltage (50/60 Hz) (V)	220 to 415	220 to 415	220 to 415
Switchable version			
. instantaneous fixed threshold (A)	0.03	0.03	-
. threshold - multiple positions (A)	0.3 - 1 - 3	0.3 - 1 - 3	0.3 - 1 - 3
- time delay (ms)	0 / 100 300 / 500	0 / 100 300 / 500	0 / 100 300 / 500
Operating display	-	yellow display resetable	yellow display resetable
Test button	•	•	•
Reset button	-	•	•
Option of sealing the settings	•	•	•
two terminals for remote control distance	•	•	•

Earth leakage protection can also be achieved by combining a circuit breaker with voltmetric release and an MTS or SHR earth leakage protection unit with separate magnetic core

Residual current earth leakage devices SHR 1100 and SHR 1110

Residual current earth leakage protection devices with separate core, which, via a Record circuit breaker or switch provide circuit opening in the event of an isolation fault.

Specially designed for industrial networks.

Functions

Isolation fault	LED indication two changeover switches
Pre-alarm 50% positive security relay	LED indication one changeover switch
Fault reset	by push-button (optional bistable relay)
System failure	manual integrated test external test
Core failure	signal 'error' and tripping

Performances

Supply voltage	V1	V2
	24V~	48V~
	110/127V~	440/480V~
version 2	220/240V~	380/415V~
version 3		
Contacts output	dry contacts 2 changeover + 1 NO	
breaking capacity	6A 250V, 1500VA max.	
insulation	4kV eff.	
Protection degree	IP20 surface IP42 flush	

Characteristics

Controlled network alternative L.V.	AC < 1000V
frequency	40 to 70Hz - 400Hz N.C.
Detection principle	measurement residual current
core ratio	600/1 (optional 470/1)
maximum current	500A - 1 s.
nominal impedance	100Ω
Current measurement	
threshold	30mA at 3.4A
pre-alarm	50% of the threshold (not adjustable)
threshold adjustm.	64 steps
indicators	4 LEDs
Power supply	
frequency	40 to 400Hz
standard voltage	24 to 480V~ in 3 ranges
consumption	4VA
Operating time	
adjustments	adjustable on SHR 1110 0.1 to 1.5 s. in 16 steps
instantaneous	15 ms bypass if 30mA threshold

Continued on A.16

The earth leakage protection units are:

- protected against untimely tripping (non-release with 250A 8/20 micro-second, defined in IEC 947.2 appendix B)
- adapted to continuous pulse bi-directional and uni-directional components (class A).

The electronic card is powered by 3 phases: protection is thus guaranteed even with loss of one phase.

D125M earth leakage protection circuit breaker



SHR 1100 - SHR 1110 (Continued from A.15)

Presentation

- Modular box 4 modules - DIN 43880
- Mounting on symmetrical rail (surface or flush)
- Screw terminals for 2.5 mm² wires
- Front face setting
- Sealable transparent cover

Remarks

1. Ensure cover conductors are centered
2. If the neutral is not out, enclose the 3 phases
3. Never allow the core to enclose the protection conductor
4. Armoured cable obligatory for cable lengths (SHR / core) ≥ 5 m or for sensitive settings ≥ 1 A

Cores CITO - CITF

- Ratio: 600/1
- Connection by box type terminals for wires of 2.5 mm²
- Connection to earth leakage protection relays using armoured cable with two insulated conductors and the shortest possible cabling (resistance < 30Ω)

MTS earth leakage protection units with separate magnetic core

Function and use

Maximum current earth leakage protection relay with separate magnetic core which uses a circuit breaker or switch Record release to open a circuit in the event of an isolation fault. Specially designed for industrial networks.

Characteristics

	MTS
Alternate earth neutral network protected	•
Frequency	50 to 175Hz
Setting values	fixed 0.03A adjustable 0.1 to 1A
Time delay	0 to 500 ms (for 0.1 to 1A)
Outgoing contacts	2 changeover contacts (2A/250V cos φ 0.3)
Display	•
Test button	•
Reset button	•

Power

Frequency 50/60 Hz
AC 220/240V or 380/415V

Mounting

Recessible into the bottom of the housing

Detection core

Passing diameter: 34, 55, 70, 100 mm
(shipped with MTS)
Detection core ratio:
- signal: 34: 230/1
55: 200/1
70: 200/1
100: 280/1
- test: 34, 55, 70, 100: 200/1

Connection diagram

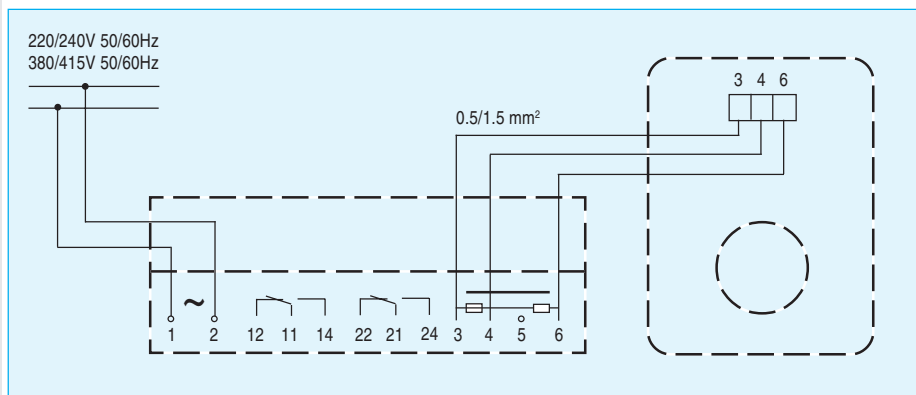

Connection diagram

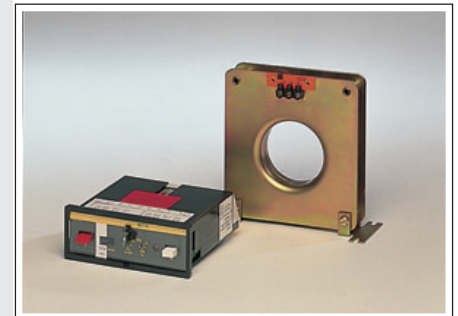
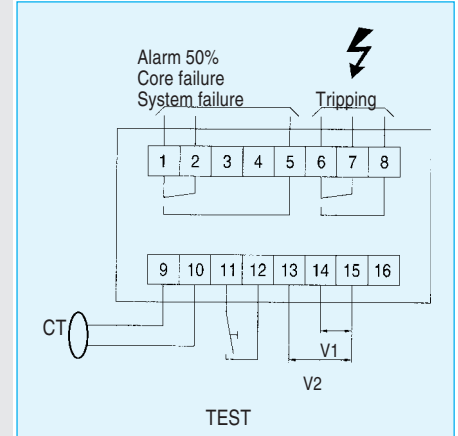

Detection core mounting

On armoured cable

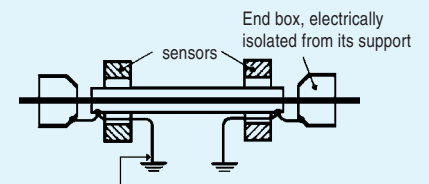

Flexible connection common to cable's ring and fuse, at cable end box

For junction boxes

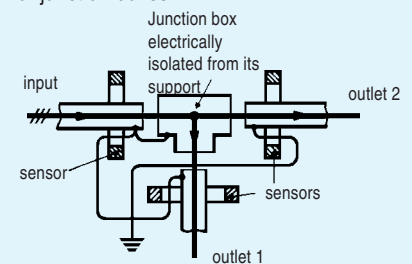

Notes

1. ensure conductors are centred on the core
2. if neutral is not out, enclose the 3 phases
3. never allow the protection conductor to be enclosed by the core

V, VR, VE visible isolation circuit breakers

General

Visible isolation circuit breakers can be used:

- for general low voltage protection of low voltage metering, high/low voltage sub stations
- wherever personnel safety implies visually clear separation of source and loads.

Conforms to NF C 13-100 and NF C 15-100 standards as well as the decree of 14/11/1988. Based on standard withdrawable circuit breakers and can receive the auxiliaries and accessories for these units.

Structure

Type of circuit breaker	Version		
	V	VR	VE
D160-D250 DH160-DH250	V	-	VE
D160 L/M D250 L/M	-	-	VE
D400-D630 DH400-DH630 D400 L-D630 L	V	VR	VE
D800 DH800	V	-	-
D1250	V	-	-

Version V



Characteristics

- 2 stable circuit breaker positions: "plugged in" "withdrawn"
- Isolation by handle or crank
- Padlocking in "removed" position
- Option of locking off in "withdrawn" position with lock (not supplied):
 - Ronis type 1104 right opening or Profalux KS 5B 20 D4Y for D160/D250
 - Ronis type 1104 right opening or Ronis EL 11 AP, or Profalux KS 5B 20 D4Y or Profalux V11 - 18 for D400
 - Ronis type 1104 left opening or Profalux KS 5B 20 G4Y for D630 - D800 - D1250
- Front connections

Version VR



Characteristics

- 2 stable circuit breaker positions: "plugged in" "withdrawn"
- Isolation by handle or crank
- Padlocking in "removed" position
- Option of locking off in "withdrawn" position with lock (not supplied):
 - Ronis type 1104 right opening or Profalux KS 5B 20 D4Y or Profalux KS 5B 20 D4Y or Profalux V11 - 18 for D400
 - Ronis type 1104 left opening or Profalux KS 5B 20 G4Y for D630
- Rear connections

Version VE



Characteristics

- 2 stable circuit breaker positions: "plugged in" "withdrawn"
- Padlocking in "removed" position
- Option of locking off in "withdrawn" position with lock (not supplied):
 - Ronis type 1104 left opening or Ronis EL 11 AP, or Profalux KS 5B 20 G4Y or Profalux V11 - 18
- Front connections



Electrical auxiliaries

Auxiliary AS "ON/OFF" switches

Changeover contact operated simultaneously with circuit breaker poles.
Easy on-site clip-on installation, no calibration needed.

		D125 to D250	D400 to D1250
Rated thermal current I _{th}		5A	5A
Rated breaking capacity			
AC	125 V	6A	10A
	220 V	5A	10A
	250 V	5A	10A
	380 V	5A	10A
DC	120 V	0.6A	0.6A
Resistance circuit			

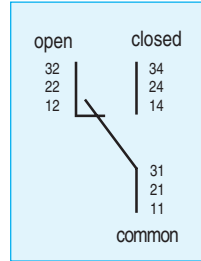

Wiring colour code:
 12 - 22 - 32: OG (orange)
 14 - 24 - 34: RD (red)
 11 - 21 - 31: BN (brown)

BA bell alarm contacts

Changeover switch displays the "tripped" position of the circuit breaker when initiated by the thermal magnetic release.
Easy on-site clip on installation, no calibration needed.

		D125 to D250	D400 to D1250
Rated thermal current I _{th}		5A	5A
Rated breaking capacity (A)			
AC	125 V	6A	5A
	220 V	5A	5A
	250 V	5A	5A
DC	120 V	0.6A	0.6A
resistance circuit			

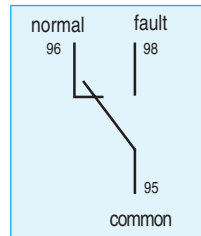

Wiring colour code:
 96: OG (orange)
 98: RD (red)
 95: BN (brown)



Electrical auxiliaries

Shunt trip release ST

Trips the circuit breaker as soon as voltage is applied.
 An intergrated auto-cut-off cuts power.
 Tripping occurs for any voltage between 70 and 110 % of nominal control voltage.
 The circuit breaker must be reset after tripping.
 Easy on-site installation with no need for calibration

	D125	D160/250	D400 to 800	D1250
Rated voltage AC and DC	24-48-110/127- 220/250- 380/440- 500/550	24-48-92/127- 180/250- 380/500	24-48-110/127 220/250- 380/415- 440/500	24-48-110/127- 220/240- 380/415- 440/500
Current consumption				
AC (VA)	100	100	60	45
DC (W)	100	100	60	50
Release breaking time (ms)	15	15	15	15

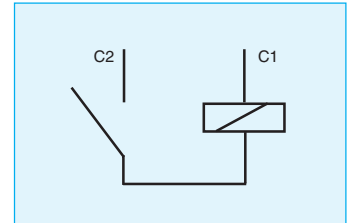

Wiring colour code:
C1 - C2: GN (green)

Undervoltage release UV

Opens the circuit breaker when control voltage disappears or falls to $\leq 70\%$ of U_n .
 Closing of the circuit breaker possible with control voltage 85% of U_n .
 Closing impossible for control voltage $\leq 35\%$ of U_n .
 In some cases the circuit breaker must be reset after tripping.
 Simple on-site clip-on installation requiring no calibration.

	D125	D160/250 ⁽¹⁾	D400 to 800 ⁽¹⁾	D1250 ⁽¹⁾
Rated voltage				
AC (V)	24-48-110/127- 220/240-380/ 415-440/500	24-48-110/127- 220/240-380/ 440-500	24-48-110/127- 220/240-380- 415/440-500	24-48-110-127- 220-380-415- 440-500
DC (V)	24-48-110/125- 220/250	24-48-110-250	24-48-110/125- 250	24-48-110-125- 250
Current consumption				
AC (VA)	8	5 (8 for 440V, 10 for 500V)	2.7	8
DC (W)	4 (6 for 250 V)	2.5 (5 for 250V)	2.5	4
Release breaking time (ms)	20	20	25	20

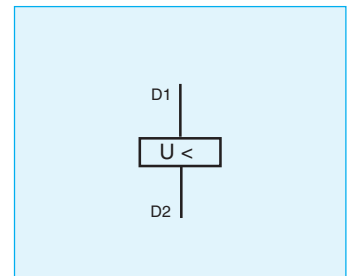

Wiring colour code:
D1 - D2: GN (green)

(1) Time delay device; 250 ms at 220V - 50Hz, 380V - 50Hz:
 avoids accidental tripping at sudden brief voltage drops.

Maximum equipment

	D125	D160/250	D400 ⁽¹⁾	D630/800 ⁽¹⁾	D1250 ⁽¹⁾
	↓ or ↓ or ↓ or ↓	↓ or ↓ or ↓	↓ or ↓ or ↓ or ↓	↓ or ↓ or ↓ or ↓	↓ or ↓ or ↓ or ↓ or ↓
ST release					
left mounting	0 0 0 0	0 1 0	0 0 0 0	0 1 0 0	0 0 1 0 1
right mounting	1 1 0 0	0 0 0	0 1 0 1	0 0 0 1	0 0 0 0 0
UV release					
left mounting	0 0 0 0	0 0 1	0 0 1 1	0 0 1 1	0 0 0 1 0
right mounting	0 0 1 1	0 0 0	0 0 0 0	0 0 0 0	0 0 0 0 1
AS contacts - 1 NO/NC					
left mounting	2 1 2 1	2 0 0	2 2 0 0	3 0 0 0	3 1 0 0 0
right mounting	0 0 0 0	2 2 2	2 0 2 0	3 3 3 0	3 3 3 3 0
BA contact - 1 NO/NC	0 1 0 1	1 1 1	1 1 1 1	1 1 1 1	0 1 1 1 1

(1) Option of 3 extra AS contacts on 4P units (except D400 4P: 2 AS contacts)
 Withdrawable version, max. equipment limited by the number of wiring isolations:
 - D160 to D400 3 and 4P, D630 3P, D800 3P: 16 wires max.
 - D630 4P, D800 4P, D1250 3 and 4P: 24 wires max.

Electrical auxiliaries

Electrical control

D125

The electrical control is fastened to the front of the unit and enables opening and closing by remote or local control.

Opening and closing is by electromagnets.
Local push-button control.

Locking off in "tripped" position by 3 padlocks (not supplied)

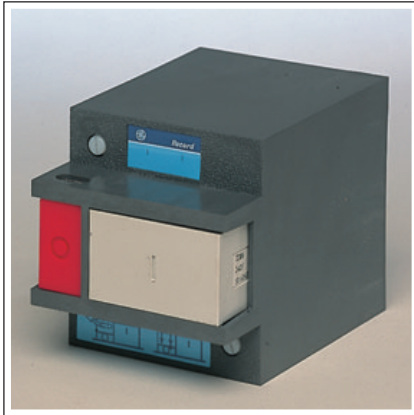

Characteristics

Nominal voltages:

- AC: 48 - 110/127 - 220/240 - 380/415 V
- DC: 24 - 48 - 110/130 - 220/250 V

Operating voltage:

- 0.85 to 1.1 Un

Power consumption:

- AC: 600 VA
- DC: 500 W

Hold power: 6 VA

Response time:

- opening/closing: 0.1 s.

Time delay between 2 successive operations: 0.1 s.

Operating diagram

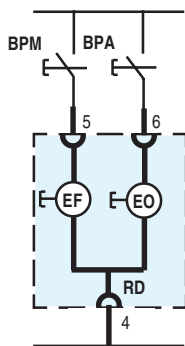

- BPA : "OFF" push button
- BPM : "ON" push button
- EF : Closing magnetic coil
- EO : Opening magnetic coil

: connection terminals

D160 - D250

Operating and closing by bidirectional motor with automatic cut-off at the end of operation.

Emergency local operation by crank

Display showing

- red: "ON"
- white: "tripped" on fault (electrical control reset)
- green: "OFF" (electrical control reset)

In the event of tripping on fault the control can be re-armed by pressing BPA.

Wiring connection by withdrawable connectors.

Locking off in "tripped" position:

- with 3 padlocks (not supplied)
- by lock Ronis type 1104 right opening supplied or Profalux type KS 5B 20D 4Y not supplied.



Characteristics

Operating voltage:

- AC: 24 - 48 - 110/127 - 220/240 V
- DC: 24 - 48 - 110/125 - 220/250 V

Operating voltage: 0.85 to 1.1 Un.

Power consumption:

- AC: 450 VA
- DC: 550 W

Response time:

- opening/closing: 0.1 s.

Time delay between 2 successive operations: 0.2 s.

Operating diagram

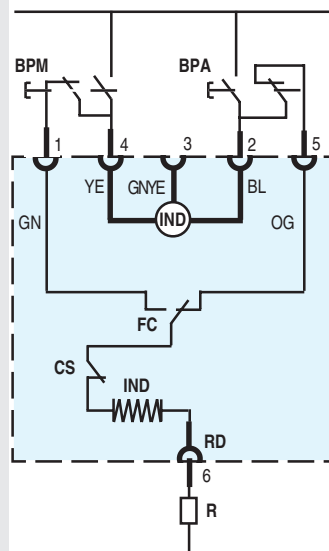

- BL : blue
- OG : orange
- YE : yellow
- GN : green
- RD : red
- BPA : "OFF" push button
- BPM : "ON" push button
- FC : limit switch
- CS : crank safety contacts
- IND : magnetic coils
- R : resistance for U > 240V

: connection terminals



Electrical auxiliaries

Electrical control

D400 to D1250

Accumulation type: an electric motor arms a spring which stores the energy required to close the breaker.

Local control.

Display showing:

- red: "ON" or "tripped" on fault (electrical control not reset)
- green: "tripped" (electrical control reset)

Wiring connection by withdrawable connectors.

Locking off in "tripped position":

- using 3 padlocks (not supplied)
- by lock Ronis type 1104, right opening supplied or Profalux type KS 5B 20 D4Y not supplied



Characteristics

Nominal voltage:

- AC: 24 - 48 - 110/127 - 220/240 - 380 - 415 V
- DC: 24 - 48 - 110/125 - 220/250 V

Operating voltage: 0.85 to 1.1 Un.

Power consumption:

- AC: 250 VA
- DC: 175 W

Response time

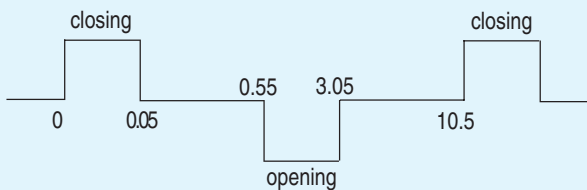

Operating diagram

The accumulation of energy (compression of a spring), required for rapid closure of the circuit breaker, takes place when the breaker opens or the electrical control is rearmed.

- closing: pressing the BPM controls power to the EF closing coil which frees the spring and operates the breaker.
- opening: pressing the BPA controls power to the motor which opens the breaker and rearms the spring.

The motor is cut at the end of travel by the limit switch FC; the breaker is then ready to engage once more.

- opening by ST or UV release, overload or short-circuit: the tripping signal engages opening of the breaker which must be rearmed by pressing the BPA or if necessary, locally by the emergency controls.

A BA fault contact can be inserted into the rearming circuit requiring manual local rearming.

In the event of a continuous engage signal (relay or switch) do not connect terminal 2 to avoid hunting.

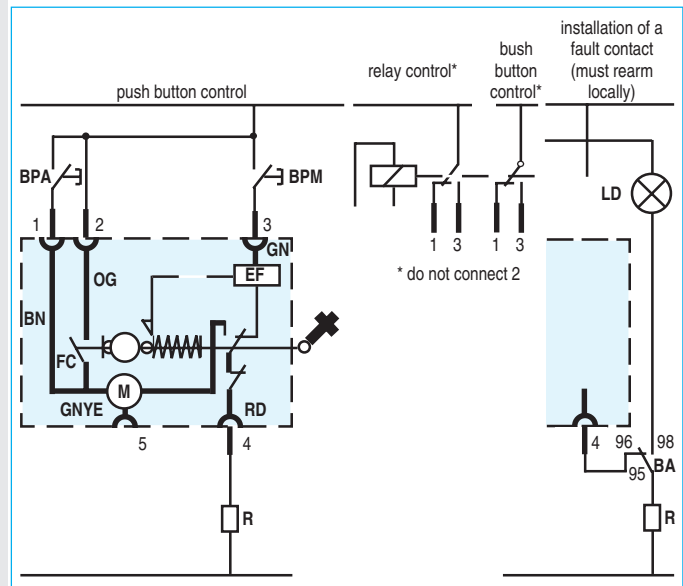

- BN : brown
- RD : red
- OG : orange
- YE : yellow
- GN : green
- GNYE : green/yellow

- BPA : "OFF"
- BPM : "ON"
- EF : electrical close
- M : motor
- FC : limit switch

R : resistance > 240V

: manual emergency control

LD : fault signal

: connection terminals

BA : fault contact

Manual rotary control

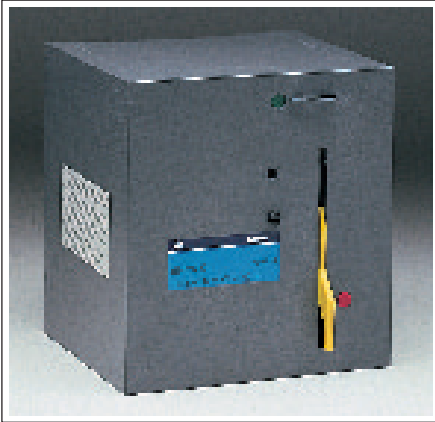

General for D125

The rotary control fastens to the front of the unit. It provides double insulation with a protection degree of:

- IP40 for controls located directly on the unit
- IP55 for controls with removable or disengageable handle.

A display indicates the exact position of the contacts:

- red: contacts closed
- white: device untripped
- green: contacts open

The fully visible isolation function is retained.

The green display appears when contacts are separated by a distance greater than 9 mm.

The three basic types are:

- direct on unit
- with removable handle for circuit breaker screwed in back of panel
- disengageable for circuit breaker behind hinged door.

General for D160 to D1250

The rotary control fastens to the front of the unit.

The rotary control is suitable in the following applications:

- fixed
- withdrawable

or installed:

- direct on breaker
- behind a screwed-on panel or a hinged door.

It provides double insulation with a protection degree of:

- IP30 for controls located directly on the unit
- IP55 for controls behind a screwed-on panel or a hinged door.

Description D160 to D1250

The handle precisely indicates the main contact positions:

- red: device 'closed'
- white: device 'tripped' on fault, by voltmetric release or 'test' button
- green: device 'open'.

The rotary control guarantees the fully isolation function and the disconnecting function (IEC 947-3).

The handle comes into the position facing the green indicator when the main contacts are separated by a distance greater than:

- 15 mm for D160-D250
- 20 mm for D400-D1250.

The interlock is not possible unless main contacts are fully open.

Basic elements for all installations

Handle

Colour

- Grey as standard
- Red for safety circuit breakers in accordance with the standard VDE 0113.

Interlock in OFF-position D125

With Ronis lock (not supplied) type 1104, 1/4 turn, right opening.

Interlock in OFF-position D160 to D1250

The handle is fitted with a retractable flap giving access to three $\varnothing 8$ padlocks only when the unit is in the 'open' position.

The Ronis lock 1104, 1/4 turn right opening is easily snapped into place, and locking and removal of the key are only possible in the 'open' position.

Interlock D125

The interlock of the mechanism prevents the opening of the door.

Basic converter

Can be fitted to the front of the circuit breaker to transform the sideways movement of the control handle into a rotary movement.

For D160 - D250

The handle can be snap-on mounted on the converter.

The handle can be removed in the 'tripped' position by a by-pass.

'ON-OFF' display contacts D125

One or two shared point changeover contacts, operating before the opening of the unit, can be mounted in the casing of devices D125.

Their characteristics are the same as those for the AS auxiliary contacts.



Exécution D160 à D1250

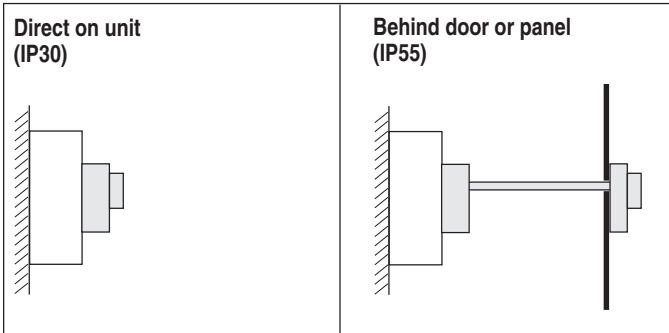

Components

Handle	
Grey or red + (lock: optional)	Grey or red + (lock: optional)
Converter	
Basic converter	Basic converter
External operator	
	<p>Door-mounted operator:</p> <ul style="list-style-type: none"> - prevents opening of the door if the circuit breaker is not 'open' - memorises the opening position - prevents handle movement with door open.
Funnel (optional)	
	<p>This part eliminates the problem of tolerances and then facilitates the coupling between the external operator and the extension bar.</p>

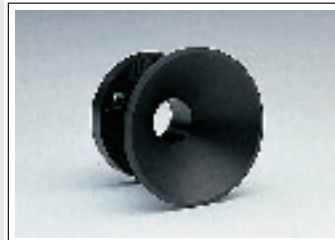
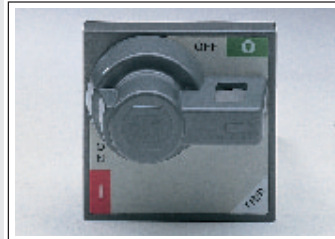
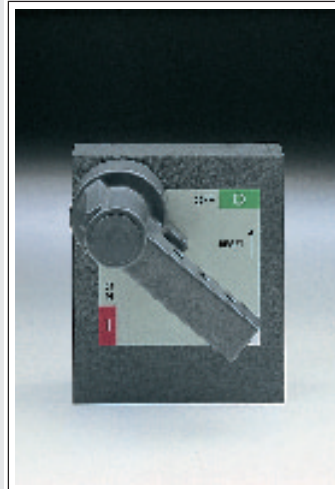

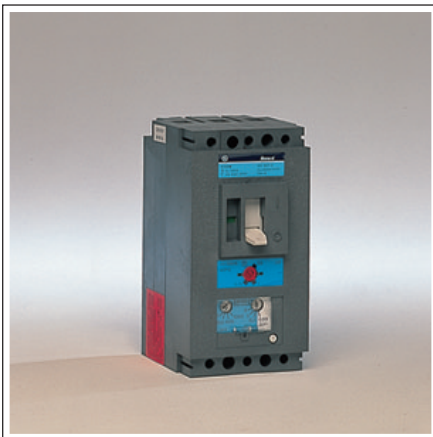
**Circuit breaker D125
Earth leakage circuit breaker
D125 M
Switch J125
Earth leakage switch J125 M**
**Fixed front
connections**
*include:
1 number*

Characteristics of circuit breakers: page A.4
 Characteristics of releases: page A.6
 Characteristics of auxiliaries: page A.18
 Dimensions: page A.102
 Connections: page A.127

Circuit breaker, fixed with front connections D125 FAV

Release type: standard

In (A)	2P - 2D	3P - 3D	4P - 3D	4P - 4D	4P - 3DN*
16	711125	711135	711155	711145	-
25	711124	711134	711154	711144	-
40	711123	711133	711153	711143	711163
63	711122	711132	711152	711142	711162
80	711121	711131	711151	711141	711161
100	711120	711130	711150	711140	711160
125	712120	712130	712150	712140	712160

Release type: A

25	711424	711434	711454	711444	
40	711423	711433	711453	711443	
63	711422	711432	711452	711442	
80	711421	711431	711451	711441	
100	711420	711430	711450	711440	
125	-	712430	-	712440	

Release type: B

16		711535	-	-	
25		711534	-	-	
40		711533	-	-	
63		711532	-	-	
80		711531	-	-	
100		711530	-	-	
125		712930	-	712940	

Switch, fixed with front connections J125 FAV

100	711020	711030	711040		
125	712020	712030	712040		

or earth leakage circuit breaker, fixed with front connections D125 M FAV

Release type: standard

16	711325	711335	711355	711345	-
25	711324	711334	711354	711344	-
40	711323	711333	711353	711343	711363
63	711322	711332	711352	711342	711362
80	711321	711331	711351	711341	711361
100	711320	711330	711350	711340	711360
125	-	712330	712350	712340	712360

Release type: A

25		711414		711474	
40		711413		711473	
63		711412		711472	
80		711411		711471	
100		711410		711470	
125		-		712470	

Release type: B

125		712910			
-----	--	--------	--	--	--

Earth leakage switch, fixed with front connections J125 M FAV

100	-	711031	711041		
125	712021	712031	712041		

* Protected neutral 50%

Fixed rear connections

include:
2 numbers



1) Circuit breaker or switch, fixed front connections (numbers: see page A.24)

2) Rear connections (1 set per pole)

bars or cables with lugs

721721 RBAR



Withdrawable front connections

include:
2 numbers



1) Circuit breaker or switch fixed front connections (numbers: see page A.24)

2) Complete withdrawable unit, front connections

ED for D125/J125

2 P	3 P	4P
721502	722503	722504

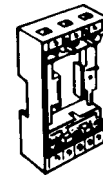

EDM for D125 M/J125 M

721542	722543	722544
--------	--------	--------

Withdrawable rear connections

include:
3 numbers



1) Circuit breaker or switch, fixed front connections (numbers: see page A.24)

2) Complete withdrawable unit with front connections

ED for D125/J125

2 P	3 P	4P
721502	722503	722504

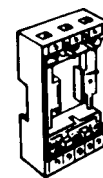

EDM for D125 M/J125 M

721542	722543	722544
--------	--------	--------

3) Rear connections (1 set per pole)

bars or cables with lugs

721721 RBAR



Characteristics of circuit breakers: page A.4
 Characteristics of releases: page A.6
 Characteristics of auxiliaries: page A.18
 Dimensions: page A.102
 Connections: page A.127

**Limiter circuit breaker D125 L
Limiter/earth leakage circuit
breaker D125 LM**
Fixed front connections

 include:
2 numbers

1) Circuit breaker fixed front connections D125 FAV

Release type: standard

In (A)	2P - 2D	3P - 3D	4P - 3D	4P - 4D	4P - 3DN*
16	711125	711135	711155	711145	-
25	711124	711134	711154	711144	-
40	711123	711133	711153	711143	711163
63	711122	711132	711152	711142	711162
80	711121	711131	711151	711141	711161
100	711120	711130	711150	711140	711160
125	712120	712130	712150	712140	712160

Release type: A

25	711424	711434	711454	711444	
40	711423	711433	711453	711443	
63	711422	711432	711452	711442	
80	711421	711431	711451	711441	
100	711420	711430	711450	711440	
125	-	712430	-	712440	

Release type: B

16		711535	-	-	
25		711534	-	-	
40		711533	-	-	
63		711532	-	-	
80		711531	-	-	
100		711530	-	-	
125		712930	-	712940	

or D125 M FAV

Release type: standard

16	711325	711335	711355	711345	-
25	711324	711334	711354	711344	-
40	711323	711333	711353	711343	711363
63	711322	711332	711352	711342	711362
80	711321	711331	711351	711341	711361
100	711320	711330	711350	711340	711360
125	-	712330	712350	712340	712360

Release type: A

25		711414		711474	
40		711413		711473	
63		711412		711472	
80		711411		711471	
100		711410		711470	
125		-		712470	

Release type: B

125		712910			
-----	--	--------	--	--	--

* Protected neutral 50%

2) Limiter unit

L125

2 P	3 P	4 P
721022	721023	721024

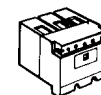
 Characteristics of circuit breakers: page A.4
 Characteristics of releases: page A.6
 Characteristics of auxiliaries: page A.18
 Dimensions: page A.102
 Connections: page A.127



Fixed rear connections

include:
3 numbers

1) Circuit breaker fixed front connections (numbers: see page A.26)

2) Limiter unit (numbers: see page A.26)

3) Rear connections (1 set per pole)

bars or cables with lugs

721721 RBAR



Withdrawable front connections

include:
3 numbers

1) Circuit breaker fixed front connections (numbers: see page A.26)

2) Limiter unit (numbers: see page A.26)

3) Withdrawable unit with front connections

EDL for D125 L

2 P	3 P	4P
721562	722563	722564

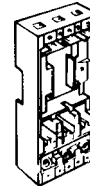

EDLM for D125 LM

721545	722546	722547
--------	--------	--------

Withdrawable rear connections

include:
4 numbers

1) Circuit breaker fixed front connections (numbers: see page A.26)

2) Limiter unit (numbers: see page A.26)

3) Complete withdrawable unit, front connections

EDL for D125 L

2 P	3 P	4P
721562	722563	722564

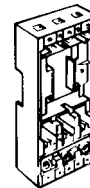

EDLM for D125 LM

721545	722546	722547
--------	--------	--------

4) Rear connections (1 set per pole)

bars or cables with lugs

721721 RBAR

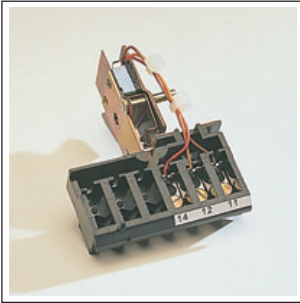

Characteristics of circuit breakers: page A.4
Characteristics of releases: page A.6
Characteristics of auxiliaries: page A.18
Dimensions: page A.102
Connections: page A.127

Auxiliaries
Display contacts

721460	1 AS
721461	2 AS
721468	1 BA
721466	1 AS+1 BA

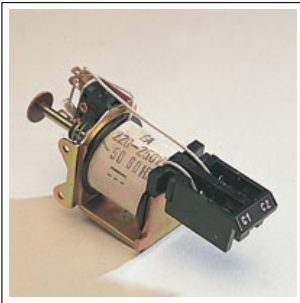
ST shunt trip release

AC 50, 60 Hz - DC

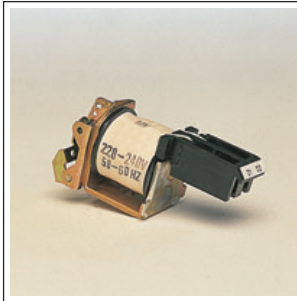
721401	24V
721402	48V
721403	110/127V
721405	220/250V
721407	380/440V
721408	500/550V

UV undervoltage release

AC 50, 60 Hz

721431	24V
721432	48V
721433	110/127V
721435	220/240V
721437	380/415V
721438	440/500V

DC

721441	24V
721442	48V
721443	110/125V
721445	220/250V

UV + time delay
AC 50 Hz

721439	220V
721440	380V

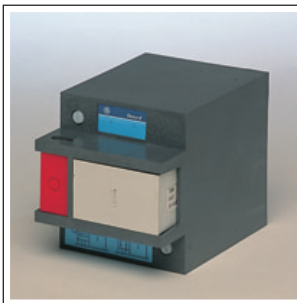
Electrical control

AC 50, 60 Hz

721642	48V
721643	110/127V
721645	220/240V
721647	380/415V

DC

721651	24V
721652	48V
721653	110/125V
721655	220/250V

Rotary controls
Direct on the apparatus

721600	CRPN	
Grey handle		
721601	CRPR	
Red handle		

With removable handle for the apparatus screwed to rear of panel

721610	CRAPN	
Grey handle		
721611	CRAPR	
Red handle		

Disengageable for the apparatus behind hinged doors

721620	CRDPN	
Grey handle		
721621	CRDPR	
Red handle		

Auxiliary contacts

721608	AS 1 NO/NC
721609	AS 2 NO/NC

Locking the rotary manual control mechanism

721626	Circuit breaker behind door in "OFF" position using lock (not supplied)
---------------	---

Mechanical locking

721627	Preventing opening of the circuit breaker in the "ON" position
---------------	--

Accessories

Terminal covers

Two multipole, sealable terminal covers for fixed device with front connections

721783	2-3 P
721784	4 P

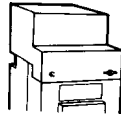

Locking control handle in the "OFF" position

With removable section for 3 padlocks, (not supplied)

721900

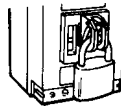

Wiring isolation

Device enabling connection of 8 circuits.
Possible mounting: 1 unit

721760 complete

721761 fixed part
721762 moving part

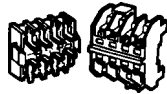

Rating error prevention

Device preventing insertion of a breaker with a different rating

721590

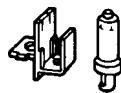

Door frame

718440

Components for withdrawable unit

Fixed part (base)

Circuit breaker D or switch J

721512	2 P
721513	3 P
721514	4 P

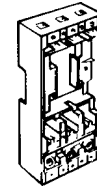

Circuit breaker D .. L

721582	2 P
721583	3 P
721584	4 P

Earth leakage circuit breaker D .. M or earth leakage switch J .. M

721572	2 P
721573	3 P
721574	4 P

Earth leakage circuit breaker D .. LM

721575	2 P
721576	3 P
721577	4 P

Moving part (pins)

721510	1 P
---------------	-----

Connection with bars

Fixed part for circuit breaker D or switch J

721585	2 P
721586	3 P
721587	4 P

Terminal cover (1 terminal)

721781	2 P
---------------	-----

Installation

Fixed device

Panel mounting

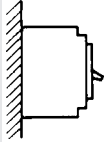

Mounting on DIN rail, 35 mm, with plate*

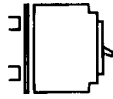

* intermediary plate: circuit breakers D - D .. L - J

721803 2 - 3 P
721804 4 P

circuit breakers D .. M - J .. M

721813 2 - 3 P
721814 4 P

Withdrawable unit

Panel mounting

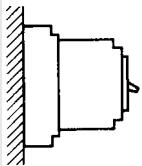

Mounting behind panel

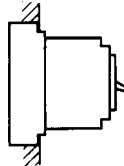

DIN rail mounting 35 mm

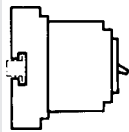

Mounting on section or bar

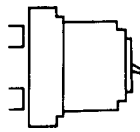

Connection (1 set per pole)

Fixed unit

Tunnel terminals for cable without lug - max. 50 mm²

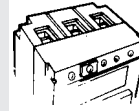

Optional:

Rear connections for bars or cables without lugs - Ø M6

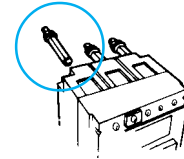

721721 RBAR

Withdrawable device

Front or rear connections cables without lugs - max. 50 mm²

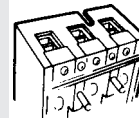

Optional:

Rear connections for bars or cables with lugs - Ø M6

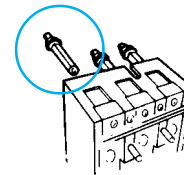

721721 RBAR

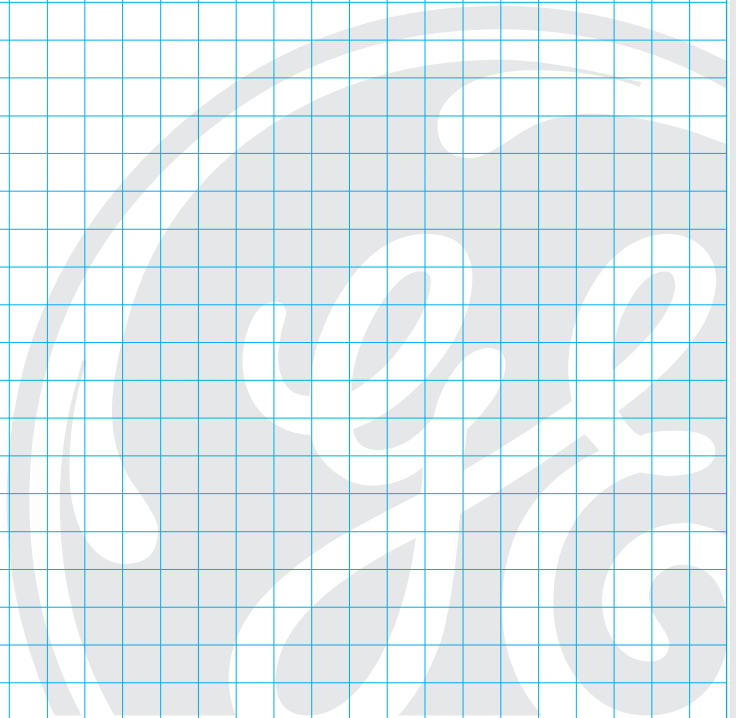

Notes

A large grid of blue lines on a white background, intended for taking notes. The grid covers most of the page area below the 'Notes' header.

**Circuit breaker D160 - DH160
Switch J160**
Fixed front connections

 include:
1 number

Circuit breaker, fixed front connections D160 FAV

Release type: standard

In (A)	3P - 3D	4P - 3D	4P - 4D	4P - 3DN*	
25	713135	713155	713145	-	
40	713134	713154	713144	713164	
63	713133	713153	713143	713163	
100	713132	713152	713142	713162	
125	713131	713151	713141	713161	
160	713130	713150	713140	713160	

Release type: A

125	713431	713451	713441		
160	713430	713450	713440		

Release type: B

40	713934	-			
63	713933	-			
100	713932	-			
125	713931	713951			
160	713930	713950			

Release type: SM

100	713939				
125	713938				
160	713937				

Switch, fixed front connections J160 FAV

160	713030	713040			
-----	--------	--------	--	--	--

Circuit breaker, fixed front connections DH160 FAV

Release type: standard

25	713235	713255	713245	-	
40	713234	713254	713244	713264	
63	713233	713253	713243	713263	
100	713232	713252	713242	713262	
125	713231	713251	713241	713261	
160	713230	713250	713240	713260	

Release type: A

125	713411		713471		
160	713410		713470		

Release type: B

125	713911				
160	713910				

Release type: SM

100	713919				
125	713918				
160	713917				

* Protected neutral 50%

 Characteristics of circuit breakers: page A.4
 Characteristics of releases: page A.6
 Characteristics of auxiliaries: page A.18
 Dimensions: page A.103
 Connections: page A.127

Fixed rear connections

include:
2 numbers



1) Circuit breaker or switch, fixed front connections

(numbers: see page A.32)

2) Rear connections
(1 set per pole)

bars and cables with lugs



723721 RBFAR

or cables without lug

723722 RCFAR

Withdrawable front connections

include:
2 numbers



1) Circuit breaker or switch, fixed front connections

(numbers: see page A.32)

2) Withdrawable unit front connections

EDAV

3 P **4 P**

723503 **723504**

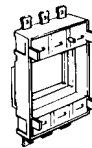

Withdrawable rear connections

include:
2 numbers



1) Circuit breaker or switch, fixed front connections

(numbers: see page A.32)

2) Withdrawable unit rear connections

EDAR

3 P **4 P**

723506 **723507**

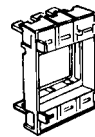

Characteristics of circuit breakers: page A.4
 Characteristics of releases: page A.6
 Characteristics of auxiliaries: page A.18
 Dimensions: page A.103
 Connections: page A.127

Limiter circuit breaker D160 L
Fixed front connections

include:
2 numbers

1) Circuit breaker fixed front connections D160 FAV

Release type: standard

In (A)	3P - 3D	4P - 3D	4P - 4D	4P - 3DN*	
25	713135	713155	713145	-	
40	713134	713154	713144	713164	
63	713133	713153	713143	713163	
100	713132	713152	713142	713162	
125	713131	713151	713141	713161	
160	713130	713150	713140	713160	

Release type: A

In (A)	3P - 3D	4P - 3D	4P - 4D	4P - 3DN*	
125	713431	713451	713441		
160	713430	713450	713440		

Release type: B

In (A)	3P - 3D	4P - 3D	4P - 4D	4P - 3DN*	
40	713934	-			
63	713933	-			
100	713932	-			
125	713931	713951			
160	713930	713950			

Release type: SM

In (A)	3P - 3D	4P - 3D	4P - 4D	4P - 3DN*	
100	713939				
125	713938				
160	713937				

* Protected neutral 50%

2) Limiter unit

L160

3 P	4 P
723023	723024

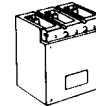

Characteristics of circuit breakers: page A.4
 Characteristics of releases: page A.6
 Characteristics of auxiliaries: page A.18
 Dimensions: page A.103
 Connections: page A.127

Fixed rear connections

include:
3 numbers

- 1) **Circuit breaker, fixed front connections** (numbers: see page A.34)
- 2) **Limiter unit** (numbers: see page A.34)

3) **Rear connections** (1 set per pole)

bars or cables with lugs

723721 RBFAR 

or cables without lug

723722 RCFAR

Withdrawable front connections

include:
4 numbers

- 1) **Circuit breaker, fixed front connections** (numbers: see page A.34)
- 2) **Limiter unit** (numbers: see page A.34)

3) **Fixed part front connections**

PAV

3 P **4 P**

723513 **723514**

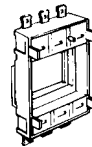

4) **Linking plate**

723526 **723527**



Withdrawable rear connections

include:
4 numbers

- 1) **Circuit breaker fixed front connections** (numbers: see page A.34)
- 2) **Limiter unit** (numbers: see page A.34)

3) **Fixed part rear connections**

PAR

3 P **4 P**

723516 **723517**

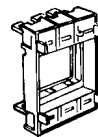

4) **Linking plate**

723526 **723527**



Characteristics of circuit breakers: page A.4
 Characteristics of releases: page A.6
 Characteristics of auxiliaries: page A.18
 Dimensions: page A.103
 Connections: page A.127

**Earth leakage circuit breaker
D160 M - DH160 M
Earth leakage switch J160 M**
Fixed front connections

 include:
2 numbers

1) Circuit breaker or switch, fixed front connections (numbers: see page A.32)

2) Earth leakage unit

M160

3 P

4 P

723013

723014

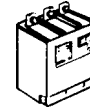
or
to order: D160 M FAV with standard release
1 number

In (A)	3P - 3D	4P - 4D	4P - 3DN*
25	713515	713525	-
40	713514	713524	713544
63	713513	713523	713543
100	713512	713522	713542
125	713511	713521	713541
160	713510	713520	713540

* Protected neutral 50%



Fixed rear connections

include:
3 numbers

- 1) Circuit breaker or switch, fixed front connections
(numbers: see page A.32)
- 2) Earth leakage unit (numbers: see page A.36)
- 3) Rear connections (one set per pole)

bars or cables with lugs

723721 RBFAR



or cables without lug

723722 RCFAR

Withdrawable front connections

include:
4 numbers

- 1) Circuit breaker or switch fixed, front connections
(numbers: see page A.32)
- 2) Earth leakage (numbers: see page A.36)
- 3) Fixed part front connections

PAV

3 P

4 P

723513

723514

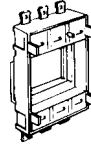

4) Linking plate

723523

723524



Withdrawable rear connections

include:
4 numbers

- 1) Circuit breaker or switch, fixed front connections
(numbers: see page A.32)
- 2) Earth leakage unit
(numbers: see page A.36)
- 3) Fixed part rear connections

PAR

3 P

4 P

723516

723517

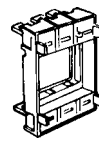

4) Linking plate

723523

723524

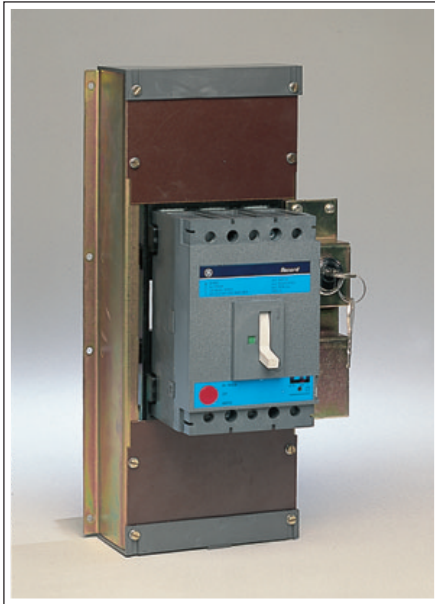

Dimensions: page A.103
Connections: page A.127

**Visible isolation circuit breaker
D160 VE - DH160 VE
Visible isolation switch
J160 VE**
*include:
3 numbers*

1) Circuit breaker or switch, fixed front connections (numbers: see page A.32)

2) Withdrawable unit front connections

EDAV

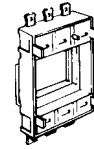
3 P	4 P
723503	723504

3) Visible isolation device

Locking in removed position (lock not supplied)

VE160

3 - 4 P
723550

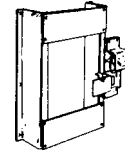
or
to order: D160 VE DAV with standard release
1 number

In (A)	3P - 3D	4P - 4D	4P - 3DN*
63	713613	713623	713643
100	713612	713622	713642
125	713611	713621	713641
160	713610	713620	713640

* Protected neutral 50%

**Visible isolation circuit breaker
D160 LVE**
**Withdrawable front
connections**
*include:
5 numbers*
1) Circuit breaker or switch, fixed, front connections (numbers: see page A.32)

2) Fixed part, front connections

PAV

3 P	4 P
723513	723514

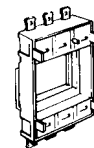
3) Visible isolation device

Locking in removed position (lock not supplied)

VE160

3 - 4 P
723550

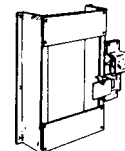
4) Limiter unit

L160

3 P	4 P
723023	723024

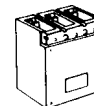
5) Linking plate

3 P	4 P
723526	723527

 Dimensions: page A.110
Connections: page A.127

Visible isolation earth leakage circuit breaker D160 MVE - DH160 MVE

Visible isolation earth leakage switch J160 MVE

Withdrawable front connections

include:
5 numbers

1) Circuit breaker or switch, fixed front connections (numbers: see page A.32)

2) Fixed part front connections

PAV

3 P	4 P
723513	723514

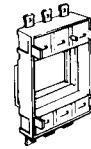

3) Visible isolation device

Locking in removed position (lock not supplied)

VE160

3 - 4 P
723550

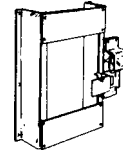

4) Earth leakage unit

M160

3 P	4 P
723013	723014

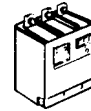

5) Linking plate

3 P	4 P
723523	723524

Visible isolation circuit breaker D160 V - DH160 V

Visible isolation switch J160 V

include:
2 numbers

1) Circuit breaker or switch, fixed front connections (numbers: see page A.32)

2) Visible isolation unit

V160

3 P	4 P
723533	723534

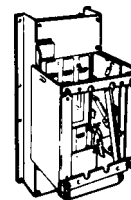

or

to order: D160 V DAV with standard release

1 number

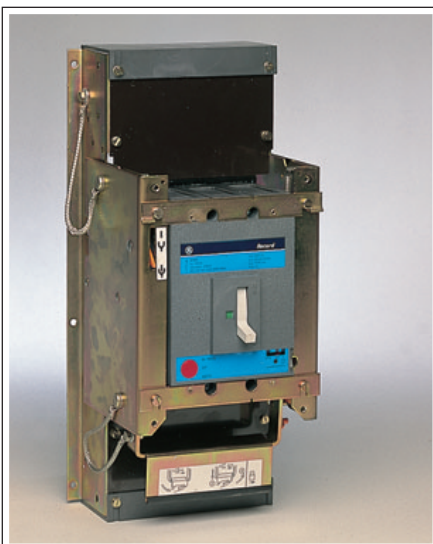

In (A)	3P - 3D	4P - 4D	4P - 3DN*
63	713663	713673	713693
100	713662	713672	713692
125	713661	713671	713691
160	713660	713670	713690

* Protected neutral 50%

Dimensions: page A.110
Connections: page A.127

Rotary controls
Display contacts

723460	1 AS
723461	2 AS
723468	1 BA
723466	1 BA + 1 AS
723467	1 BA + 2 AS

Behind door or panel
ST shunt trip release

AC 50, 60 Hz - DC

723401	24V
723402	48V
723403	92/127V
723405	180/250V
723407	380/500V

UV undervoltage release

AC 50 Hz

723431	24V
723432	48V
723433	110/127V
723435	220/240V
723437	380/440V
723438	500V

DC

723441	24V
723442	48V
723443	110V
723446	250V

UV + time delay
AC 50 Hz

723495	220V
723497	380V

Electrical control

AC 50, 60 Hz

723646	24V
723647	48V
723648	110/127V
723649	220/240V

DC

723641	24V
723642	48V
723643	110/125V
723645	220/250V

Locking off the control

in the "OFF" with lock Ronis 1104 (supplied)

723575
Direct on the apparatus
723660 CRDG

Grey handle

723661 CRDR

Red handle

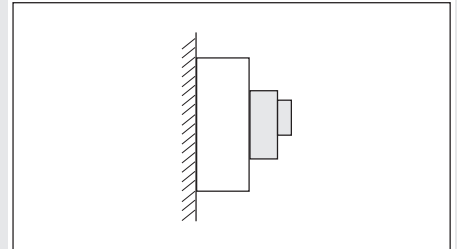
723680 CRDPG

Grey handle

723681 CRDPR

Red handle

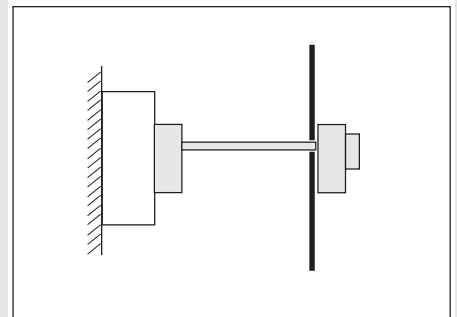

Lock (Ronis 1104)
769080

Funnel
769090

Accessories for withdrawable unit
Terminal covers

One multipole sealable terminal cover for device, fixed, with front connections

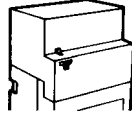
- 723783** 3 P
- 723784** 4 P

Locking the control handle in the "OFF" position

Using removable section for 3 padlocks (not supplied)

723900

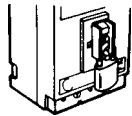

Using device for 3 padlocks (not supplied) and/or Ronis lock type 1104, 1/4 turn, left opening or Profalux type KS 5B 20 G 4Y

723901

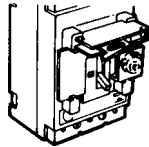

Wiring isolation

Device enabling connection of 8 circuits

Mounting options: 2 devices

723760 complete

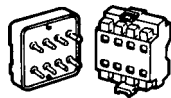
723761 fixed part
723762 moving part

Rating error prevention

Device preventing insertion of a breaker with a different rating

723590

Door frame

721644

Ronis lock 1104

755960 Right opening

755961 Left opening

Fixed part

DAV

- 723513** 3 P
- 723514** 4 P

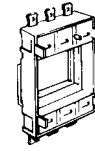

DAR

- 723516** 3 P
- 723517** 4 P

Linking plate L

- 723526** 3 P
- 723527** 4 P

Linking plate M

- 723523** 3 P
- 723524** 4 P

Moving part (pins)

- 723510** 1 P

Locking in the "removed" position

Using lock (not supplied) (version V and VE)

723530

Removal safety device

723508

Mounting Fixed device

Panel mounting

Mounting on DIN rail,
35 mm, with plate*

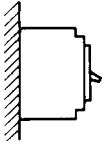

Mounting on rail or
section with plate*

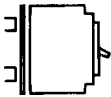

* intermediary plate:
for 35 mm DIN rail

723803 3 P
723804 4 P

for rail or section
D, D ... H, J

723823 3 P
723824 4 P

D ... L
D ... M, J ... M

723833 3 P
723834 4 P

Withdrawable device

Panel mounting

Mounting behind panel

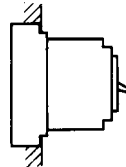
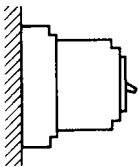

Mounting on section or
on bars

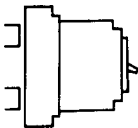

Connection (1 set per pole) Fixed device

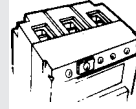

Front connections for bars
or cables with lugs.
Width 22 mm, screw M6

Optional:

Extenders for bars or
cables with lugs - Width
22 mm, holes Ø 9

Rear connections for
bars or cables with lugs
- Ø M8

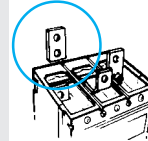

RBPFAV
723712

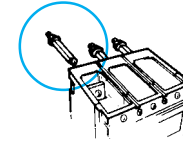

RBFAR
723721

Terminals for cables without lugs - connection capacity 95 mm²
for front connections sloping terminals rear connections

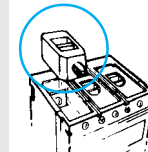

RCFAV
723711

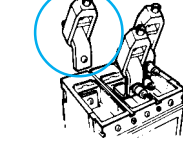

RICFAV
723713

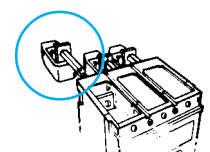

RCFAR
723722

Withdrawable device

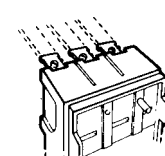
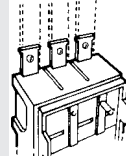

Front or rear on fixed
part, sections for bars
or cables with lugs
Width 20 mm,
holes Ø 8,5

Optional:

Extenders for bars or cables with lugs - Width 20 mm, holes Ø 9
front extender rear extender

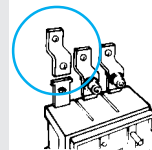

RBPDAV
723732

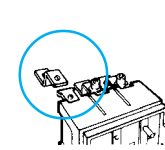

RCDAR
723741

Terminals for cables without lugs - connection for 95 mm²
front connections sloped terminals rear connections

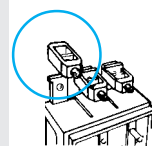

RCDAV
723731

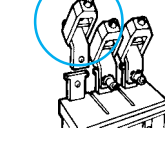

RICDAV
723733

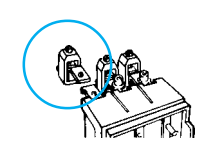

RCDAR
723742



Notes

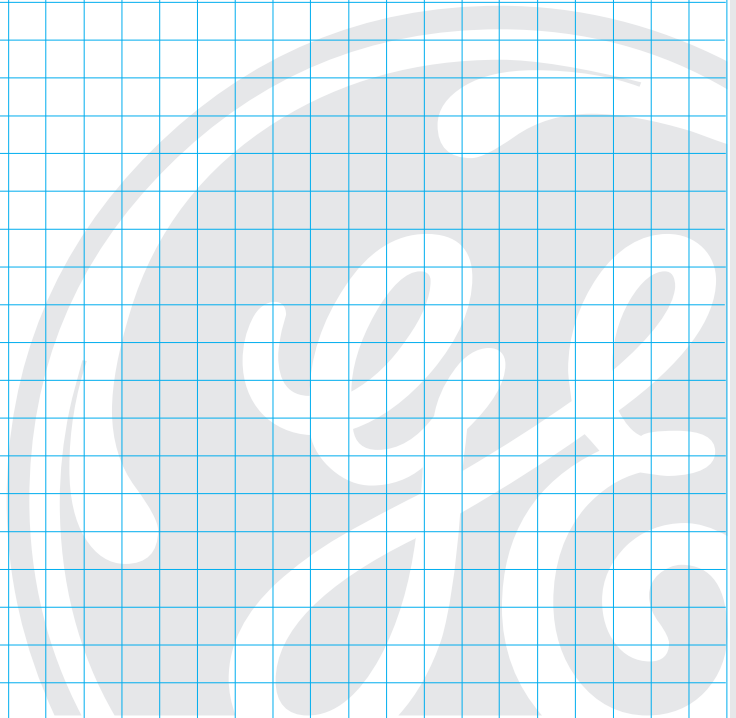
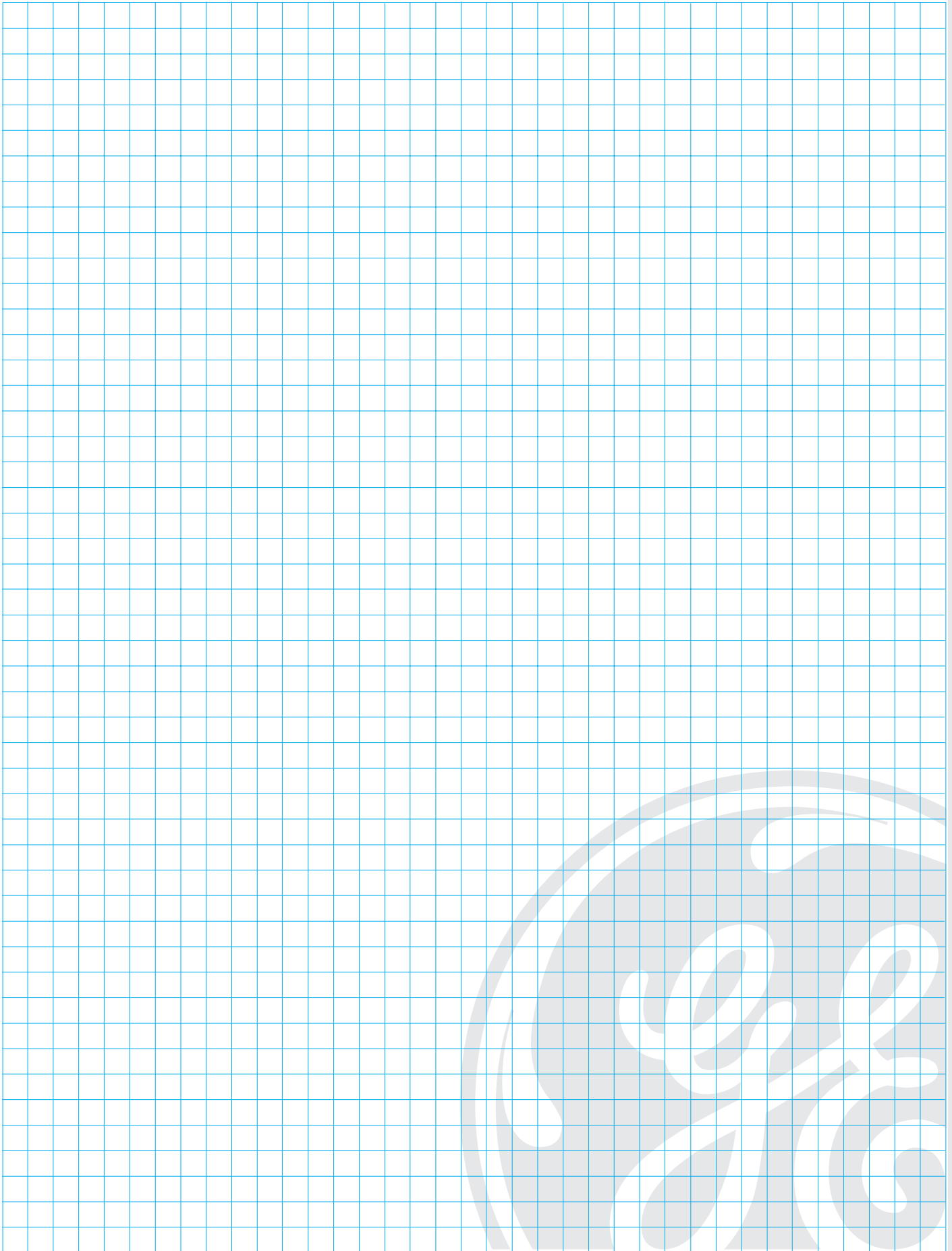

**Circuit breaker D250 - DH250
Switch J250**

Fixed, front connections

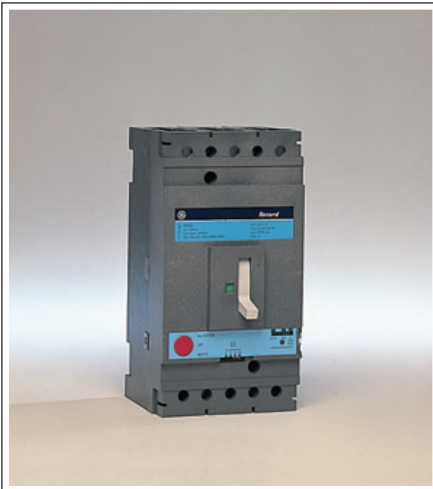
 include:
1 number

Circuit breaker fixed, front connections D250 FAV

Release type: standard

In (A)	3P - 3D	4P - 3D	4P - 4D	4P - 3DN*	
100	714134	714154	714144	-	
125	714133	714153	714143	-	
160	714132	714152	714142	714162	
200	714131	714151	714141	714161	
250	714130	714150	714140	714160	

Release type: A

200	714431		714441		
250	714430		714440		

Release type: B

200	714931	714951			
250	714930	714950			

Release type: SM

160	714939		714949		
200	714938		714948		
250	714937		714947		

Switch, fixed front connections J250 FAV

250	714030	714040			
-----	--------	--------	--	--	--

Circuit breaker, fixed front connections DH250 FAV

Release type: standard

125	714233	714253	714243	-	
160	714232	714252	714242	714262	
200	714231	714251	714241	714261	
250	714230	714250	714240	714260	

Release type: A

200	714411			714491	
250	714410			714490	

Release type: B

250	714910				
-----	--------	--	--	--	--

Release type: SM

160	714919		714979		
200	714918		714978		
250	714917		714977		

* Protected neutral 50%

 Characteristics of circuit breakers: page A.4
 Characteristics of releases: page A.6
 Characteristics of auxiliaries: page A.18
 Dimensions: page A.103
 Connections: page A.128

Fixed rear connections

include:
2 numbers



1) Circuit breaker or switch, fixed front connections

(number: see page A.44)

2) Rear connections (1 set per pole)

bars or cables with lugs

724721 RBFAR



or cables without lugs

724722 RCFAR

Withdrawable front connections

include:
2 numbers



1) Circuit breaker or switch, fixed front connections

(number: see page A.44)

2) Withdrawable unit front connections

3 P

4 P

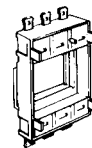

724503

724504

Withdrawable rear connections

include:
2 numbers



1) Circuit breaker or switch, fixed front connections

(number: see page A.44)

2) Withdrawable unit rear connections

EDAR

3 P

4 P

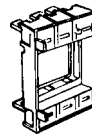

724506

724507

Characteristics of circuit breakers: page A.4
 Characteristics of releases: page A.6
 Characteristics of auxiliaries: page A.18
 Dimensions: page A.103
 Connections: page A.128

Limiter circuit breaker D250 L
Fixed front connections
*include:
2 numbers*

1) Circuit breaker, fixed front connections D250 FAV

Release type: standard

In (A)	3P - 3D	4P - 3D	4P - 4D	4P - 3DN*	
100	714134	714154	714144	-	
125	714133	714153	714143	-	
160	714132	714152	714142	714162	
200	714131	714151	714141	714161	
250	714130	714150	714140	714160	

Release type: A

200	714431		714441		
250	714430		714440		

Release type: B

200	714931	714951			
250	714930	714950			

Release type: SM

160	714939		714949		
200	714938		714948		
250	714937		714947		

* Protected neutral 50%

2) Limiter unit

L250

3 P	4 P
724023	724024



Characteristics of circuit breakers: page A.4
 Characteristics of releases: page A.6
 Characteristics of auxiliaries: page A.18
 Dimensions: page A.103
 Connections: page A.128



Fixed rear connections

include:
3 numbers

- 1) **Circuit breaker, fixed front connections** (number: see page A.46)
- 2) **Limiter unit** (number: see page A.46)
- 3) **Rear connections** (1 set per pole)

bars or cables with lugs

724721 RBFAR



or cables without lugs

724722 RCFAR

Withdrawable front connections

include:
4 numbers

- 1) **Circuit breaker, fixed front connections** (number: see page A.46)
- 2) **Limiter unit** (number: see page A.46)
- 3) **Fixed part, front connections**

PAV

3 P

4 P

724513

724514

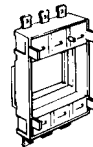

4) **Linking plate**

724526

724527



Withdrawable rear connections

include:
4 numbers

- 1) **Circuit breaker, fixed front connections** (number: see page A.46)
- 2) **Limiter unit** (number: see page A.46)
- 3) **Fixed part rear connections**

PAR

3 P

4 P

724516

724517

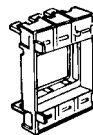

4) **Linking plate**

724526

724527



Characteristics of circuit breakers: page A.4
 Characteristics of releases: page A.6
 Characteristics of auxiliaries: page A.18
 Dimensions: page A.103
 Connections: page A.128

**Earth leakage circuit breaker
D250 M - DH250 M
earth leakage switch J250 M**
Fixed front connections
*include:
2 numbers*

1) Circuit breaker or switch, fixed front connections (number: see page A.44)

2) Earth leakage unit

M250

3 P

4 P

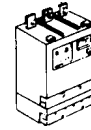

724013

724014

or
to order: D250 M FAV with standard release
1 number

In (A)	3P - 3D	4P - 4D	4P - 3DN*
160	714512	714522	714542
200	714511	714521	714541
250	714510	714520	714540

* Protected neutral 50%

Characteristics of circuit breakers: page A.4
 Characteristics of releases: page A.6
 Characteristics of auxiliaries: page A.18
 Dimensions: page A.103
 Connections: page A.128



Fixed rear connections

include:
3 numbers

1) Circuit breaker or switch, fixed front connections

(number: see page A.44)

2) Earth leakage unit

(number: see page A.48)

3) Rear connections (1 set per pole)
bars or cables with lugs

724721 RBFAR 

or cables without lugs
724722 RCFAR

Withdrawable front connections

include:
4 numbers

1) Circuit breaker or switch, fixed front connections

(number: see page A.44)

2) Earth leakage unit

(number: see page A.48)

3) Fixed part front connections

PAV

3 P **4 P**

724513 **724514** 

4) Linking plate

724523 **724524** 

Withdrawable rear connections

include:
4 numbers

1) Circuit breaker or switch, fixed front connections

(number: see page A.44)

2) Earth leakage unit

(number: see page A.48)

3) Fixed part rear connections

PAR

3 P **4 P**

724516 **724517** 

4) Linking plate

724523 **724524** 

Characteristics of circuit breakers: page A.4
Characteristics of releases: page A.6
Characteristics of auxiliaries: page A.18
Dimensions: page A.103
Connections: page A.128

**Visible isolation circuit breaker
D250 VE - DH250 VE
Visible isolation switch**

 include:
3 numbers

**Visible isolation circuit breaker
D250 LVE**

Withdrawable front connections

 include:
5 numbers

 Dimensions: page A.110
Connections: page A.128

1) Circuit breaker or switch, fixed front connections (number: see page A.44)

2) Withdrawable unit front connections

EDAV

3 P	4 P
724503	724504

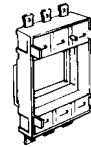
3) Visible isolation device

Locking off in removed position (lock not supplied)

VE250

3 - 4 P
724550

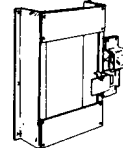

or

to order: D250 VE DAV with standard release

1 number

In (A)	3P - 3D	4P - 4D	4P - 3DN*
200	714611	714621	714641
250	714610	714620	714640

* Protected neutral 50%

1) Circuit breaker or switch, fixed front connections (number: see page A.44)

2) Fixed part front connections

PAV

3 P	4 P
724513	724514

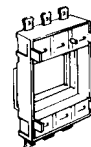
3) Visible isolation device

Locking off in removed position (lock not supplied)

VE250

3 - 4 P
724550

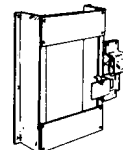
4) Limiter unit

L250

3 P	4 P
724023	724024

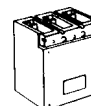
5) Linking plate

3 P	4 P
724526	724527



Visible isolation earth leakage circuit breaker D250 MVE - DH250 MVE
Visible isolation earth leakage switch J250 MVE

Withdrawable front connections

include:
5 numbers

1) Circuit breaker or switch, fixed front connections (number: see page A.44)

2) Fixed part front connections

PAV

3 P	4 P
724513	724514

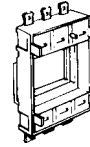

3) Visible isolation device

Locking off in removed position (lock not supplied)

VE250

3 - 4 P
724550

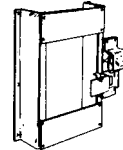

4) Earth leakage unit

M250

3 P	4 P
724013	724014

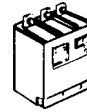

5) Linking plate

3 P	4 P
724523	724524



Visible isolation circuit breaker D250 V - DH250 V
Visible isolation switch J250 V

include:
2 numbers

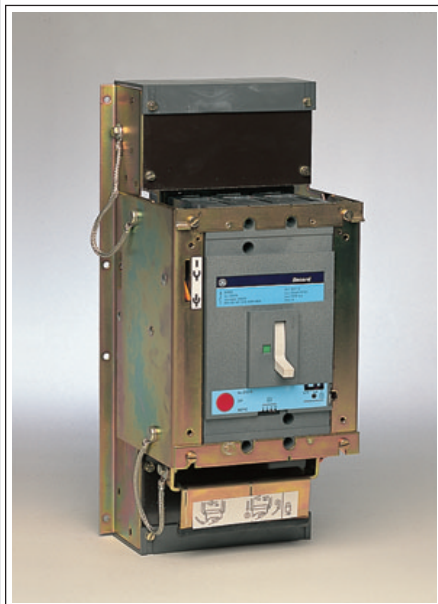

1) Circuit breaker or switch, fixed front connections (number: see page A.44)

2) Visible isolation device

V250

3 P	4 P
724533	724534

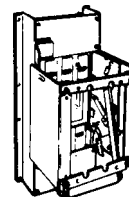

or

to order: D250 V DAV with standard release

1 number

In (A)	3P - 3D	4P - 4D	4P - 3DN*
200	714661	714671	714691
250	714660	714670	714690

* Protected neutral 50%

Dimensions: page A.110
Connections: page A.128

Auxiliaries
Display contacts

723460	1 AS
723461	2AS
723468	1 BA
723466	1 BA+1AS
723467	1 BA+2 AS

ST shunt trip release

AC 50, 60 Hz - DC

723401	24V
723402	48V
723403	92/127V
723405	180/250V
723407	380/500V

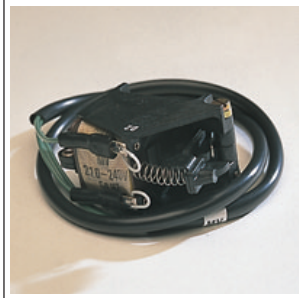
UV undervoltage release

AC 50 Hz

723431	24V
723432	48V
723433	110/127V
723435	220/240V
723437	380/440V
723438	500V

DC

723441	24V
723442	48V
723443	110V
723446	250V

UV + time delay
AC 50 Hz

723495	220V
723497	380V

Electrical control

AC 50,60 Hz

723646	24V
723647	48V
723648	110/127V
723649	220/240V

DC

723641	24V
723642	48V
723643	110/125V
723645	220/250V

Locking of the control

In "OFF" position using lock Ronis 1104 (supplied)

723575
Rotary controls
Direct on the apparatus
723660 CRDG

Grey handle

723661 CRDR

Red handle

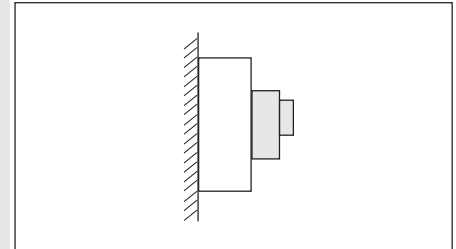
Behind door or panel
723680 CRDPG

Grey handle

723681 CRDPR

Red handle

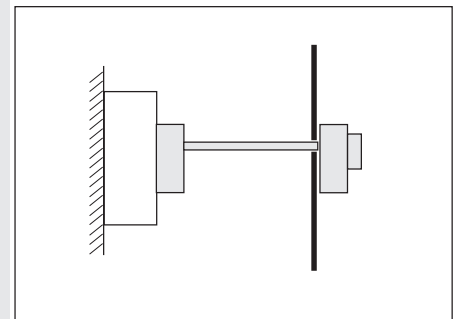

Lock (Ronis 1104)
769080

Funnel
769090

Accessories

Terminal covers

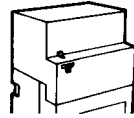
One multipole terminal cover sealable, for fixed device with front connections



723783 3 P
723784 4 P

Locking the control device in the "OFF" position

With removable section for 3 padlocks (not supplied)

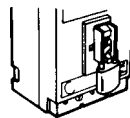

723900

Using device for 3 padlocks (not supplied) and/or Ronis type 1104 lock, 1/4 turn, left opening or Profalux type KS 5B 20 G 4Y

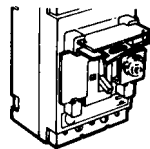

723901

Wiring isolation

Device enabling connection of 8 circuits
Mounting possible: 2 devices

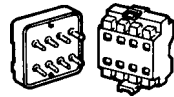

723760 complete

723761 fixed part
723762 moving part

Rating error prevention

Device preventing connection of a breaker with a different rating



723590

Door frame

721644

Ronis 1104 lock

755960 Right opening

755961 Left opening

Components for withdrawable unit

Fixed part

DAV

724513 3 P
724514 4 P

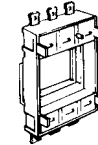

DAR

724516 3 P
724517 4 P

Linking plate L

724526 3 P
724527 4 P

Linking plate M

724523 3 P
724524 4 P

Moving part (pins)

724510 1 P

Locking in the "removed" position

Using lock, not supplied (version V and VE)

723530

Removal safety

723508

Mounting

Fixed device

Panel mounting

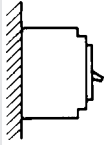

Mounting on DIN rail
35 mm, with plate*

Mounting on rail or
section with plate

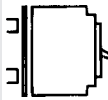

* intermediary plate:
for 35 mm DIN rail

723803 3 P
723804 4 P

for rail or section
D, D ... H, J

723823 3 P
723824 4 P

D ... L
D ... M, J .. M

723833 3 P
723834 4 P

Withdrawable device

Panel mounting

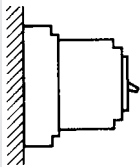

Mounting behind panel

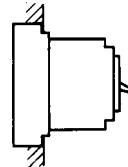

Mounting on section or bar

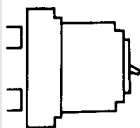

Connection (1 set per pole)

Fixed device

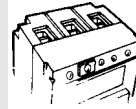

With front connections for
bars or cables with lugs
Width 25 mm, screw M8

Optional:

Extenders for bars or
cables with lugs - Width
25 mm, holes Ø 11

Rear connections for
bars or cables with lugs
- Ø M8

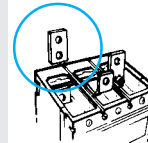

RBPFAV

724712

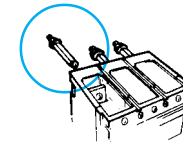

RBFAR

724721

Terminals for cables without lugs - connection capacity 120 mm²
front connections

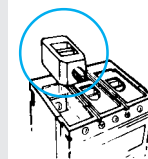

RCFAV

724711

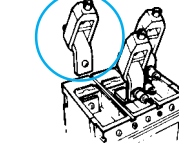

RICFAV

724713

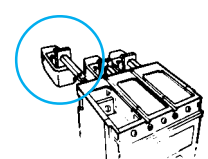

RCFAR

724722

Withdrawable device

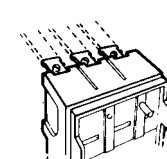
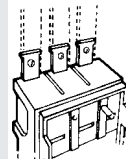

Front or rear on fixed
part, sections for bars
or cables with lugs
Width 20 mm,
holes Ø 10,5

Optional:

Extenders for bars or cables with lugs - Width 20 mm, holes Ø 10.5
front extender

rear extender

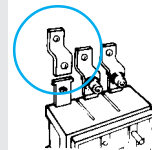

RBPDAV

724732

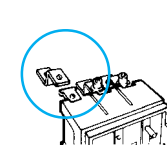

RCDAR

724741

Terminals for cables without lugs - connection capacity 120 mm²
front connections

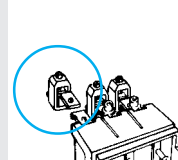

RCDAV

724731

sloped terminals

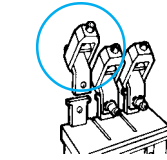

RICDAV

724733

rear connections

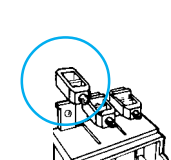

RCDAR

724742

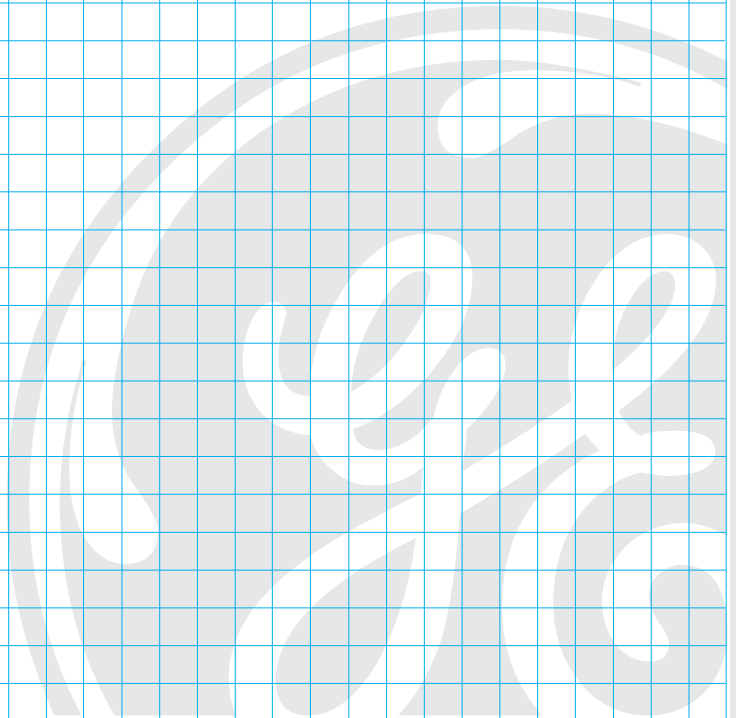

Notes

A large grid of blue lines on a white background, intended for taking notes. The grid covers most of the page area below the 'Notes' header.

**Circuit breaker D400 - DH400
 Limiter circuit breaker D400 L
 Switch J400**
Fixed front connections

 include:
2 numbers

1) Circuit breaker, fixed front connections, without release

N° P	D400 SD	DH400 SD	D400 L SD
3P	715030	715031	715032
4P	715040	715041	715042

2) Release

Release type: standard

In (A)	3P - 3D	4P - 3D	4P - 4D	4P - 3DN*	
250	715112	715132	715122	715142	
320	715111	715131	715121	715141	
400	715110	715130	715120	715140	

Release type: A

320	715211	715231	715221	715241	
400	715210	715230	715220	715240	

Release type: B

320	715261	715281			
400	715260	715280			

Release type: S

250	715162	-	715172		
320	715161	715181	715171		
400	715160	715180	715170		

 J unit ⁽¹⁾

All auxiliaries (possible installation: AS - ST- UV)

	715361	715371			
--	--------	--------	--	--	--

Lock (possible installation: AS only)

	715360	715370			
--	--------	--------	--	--	--

* Protected neutral 50%

(1) Switch J = D400 SD + J unit

or
to order: D400 FAV, DH400 FAV, D400L FAV, with standard release
1 number
D400 FAV

In (A)	3P - 3D	4P - 4D	4P - 3DN*		
250	715712	715722	715742		
320	715711	715721	715741		
400	715710	715720	715740		

DH400 FAV

250	715762	715772	715792		
320	715761	715771	715791		
400	715760	715770	715790		

D400 L FAV

250	715562	715572	715592		
320	715561	715571	715591		
400	715560	715570	715590		

* Protected neutral 50%

 Characteristics of circuit breakers: page A.5
 Characteristics of releases: page A.7
 Characteristics of auxiliaries: page A.18
 Dimensions: page A.104
 Connections: page A.128

Fixed rear connections

include:
3 numbers



- 1) **Circuit breaker fixed, without release** (number: see page A.56)
- 2) **Release or J unit** (number: see page A.56)
- 3) **Rear connections** (1 set per pole)

725723 RBPCFAR



Withdrawable front connections

include:
4 numbers



- 1) **Circuit breaker, fixed without release** (number: see page A.56)
- 2) **Release or J unit** (number: see page A.56)
- 3) **Withdrawable unit**

ED

3 P	4 P
725503	725504

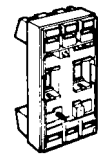

- 4) **Front connections** (1 set per pole)

725732 RBPDAV



Withdrawable rear connections

include:
4 numbers



- 1) **Circuit breaker fixed, without release** (number: see page A.56)
- 2) **Release or J unit** (number: see page A.56)
- 3) **Withdrawable unit**

ED

3 P	4 P
725503	725504

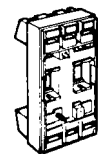

- 4) **Rear connections** (1 set per pole)

725741 RBPCDAR



Characteristics of circuit breakers: page A.5
 Characteristics of releases: page A.7
 Characteristics of auxiliaries: page A.18
 Dimensions: page A.104
 Connections: page A.128

**Earth leakage circuit breaker
D400 M - DH400 M
Earth leakage switch J400 M**
Fixed front connections

 include:
3 numbers

1) Circuit breaker, fixed front connections, without release

N° P	D400 SD	DH400 SD
3P	715030	715031
4P	715040	715041

2) Release

Release type: standard

In (A)	3P - 3D	4P - 3D	4P - 4D	4P - 3DN*	
250	715112	715132	715122	715142	
320	715111	715131	715121	715141	
400	715110	715130	715120	715140	

Release type: A

320	715211	715231	715221	715241	
400	715210	715230	715220	715240	

Release type: B

320	715261	715281			
400	715260	715280			

Release type: S

250	715162	-	715172		
320	715161	715181	715171		
400	715160	715180	715170		

 J ⁽¹⁾

All auxiliaries (possible installation: AS- ST- UV)

	715361	715371			
--	--------	--------	--	--	--

* Protected neutral 50%

(1) Switch J = D400 SD + J unit

3) Earth leakage unit M400

3P	725013
4P	725014

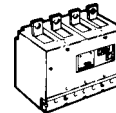

or

to order: D400 M FAV, with standard release
1 number

D400 M FAV

In (A)	3P - 3D	4P - 4D	4P - 3DN*		
250	715512	715522	715542		
320	715511	715521	715541		
400	715510	715520	715540		

* Protected neutral 50%

Fixed rear connections

 include:
4 numbers

 Characteristics of circuit breakers: page A.5
 Characteristics of releases: page A.7
 Characteristics of auxiliaries: page A.18
 Dimensions: page A.105
 Connections: page A.128

1) Circuit breaker, fixed without release (number: see above)

2) Release or J unit (number: see above)

3) Earth leakage protection unit (number: see above)

4) Rear connections (1 set per pole)

725723	RBPCFAR
--------	---------



**Visible isolation circuit breaker
D400 VE - DH400 VE - D400 LVE
Visible isolation switch
J400 VE**
Withdrawable front connections
*include:
5 numbers*

1) Circuit breaker withdrawable front connections, without release

N° P	D400 SD	DH400 SD	D400 L SD
3P	715030	715031	715032
4P	715040	715041	715042

2) Release

Release type: standard

In (A)	3P - 3D	4P - 3D	4P - 4D	4P - 3DN*
250	715112	715132	715122	715142
320	715111	715131	715121	715141
400	715110	715130	715120	715140

Release type: A

320	715211	715231	715221	715241
400	715210	715230	715220	715240

Release type: B

320	715261	715281		
400	715260	715280		

Release type: S

250	715162	-	715172	
320	715161	715181	715171	
400	715160	715180	715170	

 J unit ⁽¹⁾

All auxiliaries (possible installation: AS - ST - UV)

	715361	715371		
--	--------	--------	--	--

Lock (possible installation: AS only)

	715360	715370		
--	--------	--------	--	--

* Protected neutral 50%

(1) Switch J = D400 SD + J unit

3) Withdrawable unit

Locking in the removed position (lock not supplied)

ED

3 P	4 P
725503	725504

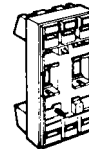
4) Front connections (1 set per pole)

725732	RBPDAV
--------	--------

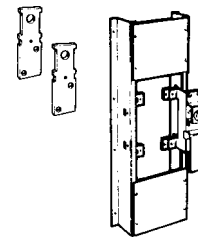
5) Visible isolation device

VE 400

3 - 4 P	725550
---------	--------

or

to order: D400 VE FAV, with standard release
1 number
D400 VE FAV

In (A)	3P - 3D	4P - 4D	4P - 3DN*
250	715612	715622	715642
320	715611	715621	715641
400	715610	715620	715640

* Protected neutral 50%

 Characteristics of circuit breakers: page A.5
 Characteristics of releases: page A.7
 Characteristics of auxiliaries: page A.18
 Dimensions: page A.111
 Connections: page A.128

**Visible isolation circuit breaker
D400 VR - DH400 VR - D400 LVR
Visible isolation switch J400 VR**
Withdrawable rear connections

 include:
4 numbers

1) Circuit breaker, fixed front connections, without release

N° P	D400 SD	DH400 SD	D400 L SD
3P	715030	715031	715032
4P	715040	715041	715042

2) Release

Release type: standard

In (A)	3P - 3D	4P - 3D	4P - 4D	4P - 3DN*	
250	715112	715132	715122	715142	
320	715111	715131	715121	715141	
400	715110	715130	715120	715140	

Release type: A

320	715211	715231	715221	715241	
400	715210	715230	715220	715240	

Release type: B

320	715261	715281			
400	715260	715280			

Release type: S

250	715162	-	715172		
320	715161	715181	715171		
400	715160	715180	715170		

 J unit ⁽¹⁾

All auxiliaries (possible installation: AS - ST - UV)

	715361	715371			
--	--------	--------	--	--	--

Lock (possible installation: AS only)

	715360	715370			
--	--------	--------	--	--	--

* Protected neutral 50%

(1) Switch J = D400 SD + J unit

3) Rear connections (1 set per pole)

725741	RBPCDAR
--------	---------

4) Visible isolation device

Locking in the removed position (lock not supplied)

VR 400

3 P	725553
4 P	725554

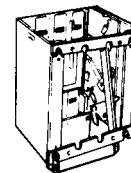

**Visible isolation circuit breaker
D400 V - DH400 V - D400 LV
Visible isolation switch
J400 V**
Withdrawable without connection

 include:
3 numbers

1) Circuit breaker fixed front connections, without release

N° P	D400 SD	DH400 SD	D400 L SD
3P	715030	715031	715032
4P	715040	715041	715042

2) Release

Release type: standard

In (A)	3P - 3D	4P - 3D	4P - 4D	4P - 3DN*	
250	715112	715132	715122	715142	
320	715111	715131	715121	715141	
400	715110	715130	715120	715140	

Release type: A

320	715211	715231	715221	715241	
400	715210	715230	715220	715240	

Release type: B

320	715261	715281			
400	715260	715280			

Release type: S

250	715162	-	715172		
320	715161	715181	715171		
400	715160	715180	715170		

 J Unit ⁽¹⁾

All auxiliaries (possible installation: AS - ST - UV)

	715361	715371			
--	--------	--------	--	--	--

Lock (possible installation: AS only)

	715360	715370			
--	--------	--------	--	--	--

* Protected neutral 50%

(1) Switch J = D400 SD + J unit

3) Visible isolation device

Locking in removed position (lock not supplied)

V 400

3 P	725533
4 P	725534

If required:

Front connections (1 set per pole)

725732	RBPDAV
--------	--------

or

Rear connections (1 set per pole)

725741	RBPCDAR
--------	---------

or
to order: D400 V without connection, with standard release
1 number
D400V

In (A)	3P - 3D	4P - 4D	4P - 3DN*		
250	715662	715672	715692		
320	715661	715671	715691		
400	715660	715670	715690		

* Protected neutral 50%

If necessary add one front or rear set of connections per pole, number: see above.

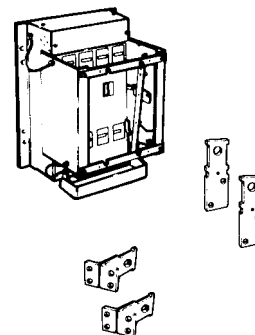
 Characteristics of circuit breakers: page A.5
 Characteristics of releases: page A.7
 Characteristics of auxiliaries: page A.18
 Dimensions: page A.111
 Connections: page A.128

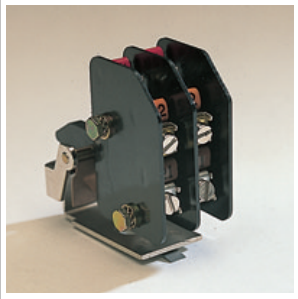
Auxiliaries
Display contacts

726460	1 AS
726461	2 AS
726468	1 BA

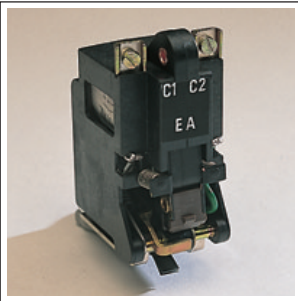
ST shunt trip release

AC 50, 60 Hz - DC

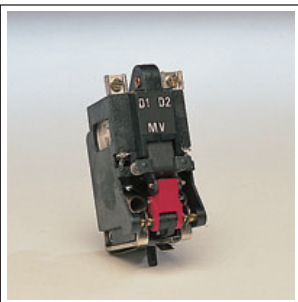
726401	24V
726402	48V
726403	110/127V
726405	220/250V
726407	380/415V
726408	440/500V

UV undervoltage release

AC 50 Hz

726431	24V
726432	48V
726433	110/127V
726435	220/240V
726437	380V
726436	415/440V
726438	500V

Characteristics of auxiliaries: page A.18

UV Undervoltage release
(contd.)

AC 60 Hz

726451	24V
726452	48V
726453	110/127V
726455	220V
726457	380/440V
726458	500V

UV + time delay AC 50 Hz

726495	220V
726497	380V

DC

726441	24V
726442	48V
726443	110/125V
726446	250V

Electrical control

AC 50/60Hz

725641	24V
725642	48V
725643	110/127V
725645	220/240V
725647	380V
725648	415V

DC

725651	24V
725652	48V
725653	110/125V
725655	220/250V

Locking of the control

In "OFF" position using lock Ronis 1104 (supplied)

726670

Rotary controls
Direct on the apparatus

725660 CRDG

Grey handle

725661 CRDR

Red handle

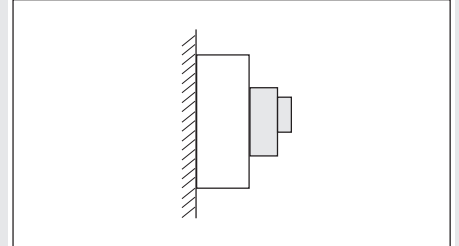

Behind door or panel

725680 CRDPG

Grey handle

725681 CRDPR

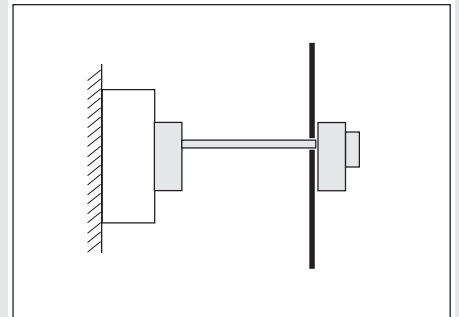
Red handle

Lock (Ronis 1104)

769080

Funnel

769090



Accessories

Terminal covers

Two multipolar, sealable terminal covers for fixed devices with front connections

725783 3 P
725784 4 P



Control handle extender

725902

Locking control handle in "OFF" position

With removable unit for 3 padlocks (not supplied)

725900

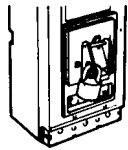

Using device for 3 padlocks (not supplied) and/or Ronis type lock 1104, 1/4 turn, right opening or Profalux type KS 5B 20 D 4Y

725901

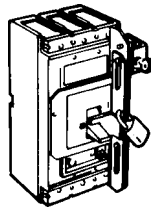

Wiring isolation

Device enabling connection of 8 circuits
Possible installation: 2 devices

723760 Complete

723761 Fixed part
723762 moving part

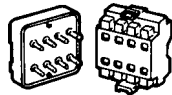

Rating error prevention

Device preventing insertion of a breaker with a different rating

726590



Door frame

725582

Ronis lock 1104

755960 Right opening

755961 Left opening

Components for withdrawable unit

Fixed part

DAV

725513 3 P
725514 4 P

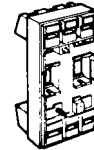

Moving part (pins)

725510 1 P

Installation

Fixed device

Panel mounting

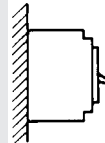

Mounting on section or bar with plate * for device with rear connections

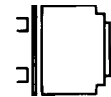

* intermediary

725823 3 P
725824 4 P

Withdrawable device

Panel mounting

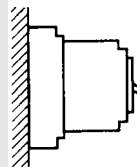

Mounting behind panel

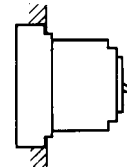

Installation on section or bar

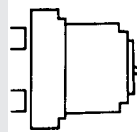

Connection (1 set per pole)
Fixed device



With front connections for bar or cables with lugs
Width 32 mm, screw M10

Optional:

Extenders for bars or cables with lugs.
Width 22 mm, holes Ø 11
flat

on narrow edge

Rear connections for bars or cables with lugs.
Width 22 mm, holes Ø 11
flat

or on narrow edge

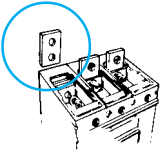

RBPFAV

725712

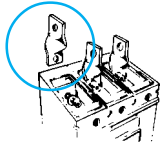

RBCFAV

725714

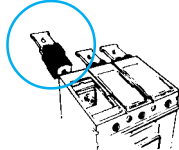

RBPCFAR

725723

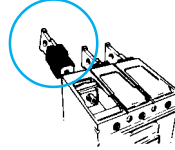

Terminals for cables without lugs - Connection capacity 95 to 240 mm²
front connections

sloped connections

rear connections

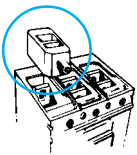

RCFAV

725711

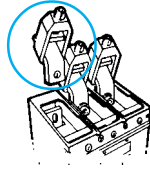

RICFAV

725710

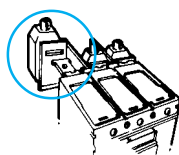

RCFAR

725722

Withdrawable device

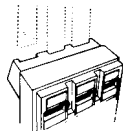
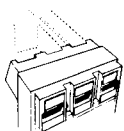

On rear of fixed part,
sections for bars.
Width 25 mm,
2 holes M6

Optional:

Extenders for bars or cables with lugs - Width 22 mm, holes Ø 11
front extenders

extenders at rear

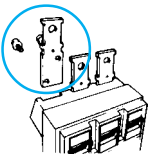

RBPDAV

725732

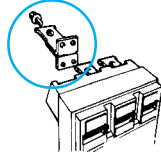

RBPCDAR

725741

Terminals for cables without lugs - Connection capacity 95 to 240 mm²
front connections

rear connections

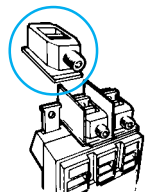

RC

725722

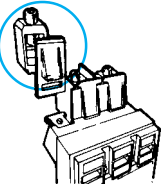

RC

725722

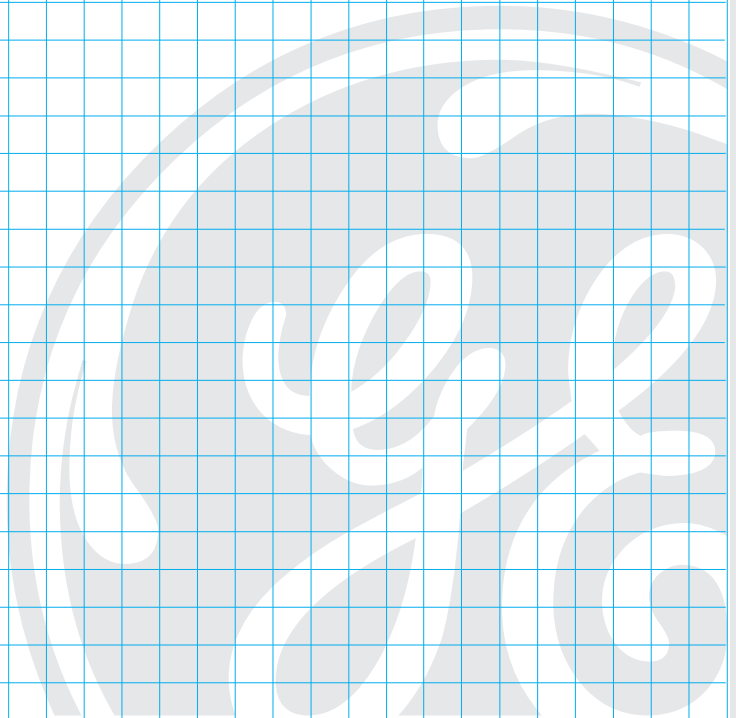

Notes

A large grid of blue lines on a white background, intended for taking notes. The grid covers most of the page area below the 'Notes' header.

**Circuit breaker
D630 - DH630 - D630 L
Switch J630**

Fixed front connections

 include:
2 numbers

1) Circuit breaker, fixed front connections, without release

N° P	D630 SD	DH630 SD	D630 L SD
3P	716030	716031	716032
4P	716040	716041	716042

2) Release

Release type: standard

In (A)	3P - 3D	4P - 3D	4P - 4D	4P - 3DN*
400	716112	716132	716122	716142
500	716111	716131	716121	716141
630	716110	716130	716120	716140

Release type: A

500	716211		716221	
630	716210		716220	

Release type: B

500	716261		716271	
630	716260		716270	

Release type: S

400	716162		716172	
500	716161		716171	
630	716160		716170	

 J unit ⁽¹⁾

All auxiliaries (possible installation: AS - ST - UV)

	716361	716371		
--	--------	--------	--	--

Lock (possible installation: AS only)

	716360	716370		
--	--------	--------	--	--

* Protected neutral 50%

(1) Switch J = D630 SD + J unit

or

to order: D630 FAV, DH630 FAV, D630 L FAV, with standard release

1 number

D630 FAV

In (A)	3P - 3D	4P - 4D	4P - 3DN*
400	716712	716722	716742
500	716711	716721	716741
630	716710	716720	716740

DH630 FAV

400	716762	716772	716792
500	716761	716771	716791
630	716760	716770	716790

D630 L FAV

400	716562	716572	716592
500	716561	716571	716591
630	716560	716570	716590

* Protected neutral 50%

 Characteristics of circuit breakers: page A.4
 Characteristics of releases: page A.6
 Characteristics of auxiliaries: page A.18
 Dimensions: page A.104
 Connections: page A.129

Fixed rear connections
include:
3 numbers

- 1) **Circuit breaker, fixed without release** (number: see page A.66)
- 2) **Release or J unit** (number: see page A.66)

- 3) **Rear connections** (1 set per pole)

726723	RBPCFAR	≤ 500A	
726733	RBPCFAR	630A	

Withdrawable front connections
include:
4 numbers

- 1) **Circuit breaker, fixed without release** (number: see page A.66)
- 2) **Release or J unit** (number: see page A.66)

- 3) **Withdrawable unit**

ED

3 P	4 P
726503	726504

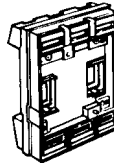

- 4) **Front connections** (1 set per pole)

726732	RBPDVA	
---------------	--------	--

Withdrawable rear connections
include:
4 numbers

- 1) **Circuit breaker, fixed without release** (number: see page A.66)
- 2) **Release or J unit** (number: see page A.66)

- 3) **Withdrawable unit**

ED

3 P	4 P
726503	726504

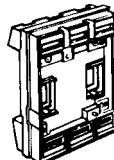

- 4) **Rear connections** (1 set per pole)

726741	RBPCDAR	
---------------	---------	--

Characteristics of circuit breakers: page A.4
 Characteristics of releases: page A.6
 Characteristics of auxiliaries: page A.18
 Dimensions: page A.104
 Connections: page A.129

**Earth leakage circuit breaker
D630 M - DH630 M
Earth leakage switch
J630 M**
Fixed front connections

 include:
3 numbers

1) Circuit breaker, fixed front connections, without release

N° P	D630 SD	DH630 SD
3P	716030	716031
4P	716040	716041

2) Release

Release type: standard

In (A)	3P - 3D	4P - 3D	4P - 4D	4P - 3DN*	
400	716112	716132	716122	716142	
500	716111	716131	716121	716141	
630	716110	716130	716120	716140	

Release type: A

500	716211		716221		
630	716210		716220		

Release type: B

500	716261		716271		
630	716260		716270		

Release type: S

400	716162		716172		
500	716161		716171		
630	716160		716170		

 J unit ⁽¹⁾

All auxiliaries (possible installation: AS - ST - UV)

	716361	716371			
--	--------	--------	--	--	--

* Protected neutral 50%

(1) Switch J = D630 SD + J unit

3) Earth leakage protection unit M630

3P	726013
4P	726014

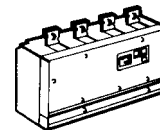

or

to order: D630 M FAV, with standard release

1 number

D630 M FAV

In (A)	3P - 3D	4P - 4D	4P - 3DN*		
400	716512	716522	716542		
500	716511	716521	716541		
630	716510	716520	716540		

* Protected neutral 50%

Fixed rear connections

 include:
4 numbers

 Characteristics of circuit breakers: page A.4
 Characteristics of releases: page A.6
 Characteristics of auxiliaries: page A.18
 Dimensions: page A.105
 Connections: page A.129

1) Circuit breaker, fixed without release (number: see above)

2) Release or J unit (number: see above)

3) Earth leakage protection unit (number: see above)

4) Rear connections (1 set per pole)

726723	RBPCFAR	400A, 500A
726733	RBPCFAR	630A



**Visible isolation circuit breaker
D630 VE - DH630 VE - D630 LVE
Visible isolation switch
J630 VE**
**Withdrawable front
connections**
*include:
5 numbers*

1) Circuit breaker, withdrawable front connections, without release

N° P	D630 SD	DH630 SD	D630 L SD
3P	716030	716031	716032
4P	716040	716041	716042

2) Release

Release type: standard

In (A)	3P - 3D	4P - 3D	4P - 4D	4P - 3DN*
400	716112	716132	716122	716142
500	716111	716131	716121	716141
630	716110	716130	716120	716140

Release type: A

500	716211		716221	
630	716210		716220	

Release type: B

500	716261		716271	
630	716260		716270	

Release type: S

400	716162		716172	
500	716161		716171	
630	716160		716170	

 J unit ⁽¹⁾

All auxiliaries (possible installation: AS - ST - UV)

	716361	716371		
--	--------	--------	--	--

Lock (possible installation: AS only)

	716360	716370		
--	--------	--------	--	--

* Protected neutral 50%

(1) Switch J = D630 SD + J unit

3) Withdrawable unit

Locking in withdrawn position (lock not supplied)

ED

3 P	4 P
726503	726504

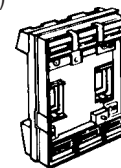
4) Front connections (1 set per pole)

726732	RBPDAV
--------	--------

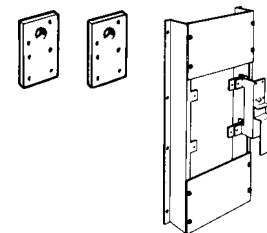
5) Visible isolation device

VE 630

3 - 4 P	726550
---------	--------

or

to order: D630 VE FAV, with standard release

1 number

D630 VE FAV

In (A)	3P - 3D	4P - 4D	4P - 3DN*
400	716612	716622	716642
500	716611	716621	716641
630	716610	716620	716640

* Protected neutral 50%

 Characteristics of circuit breakers: page A.4
 Characteristics of releases: page A.6
 Characteristics of auxiliaries: page A.18
 Dimensions: page A.111
 Connections: page A.129

**Visible isolation circuit breaker
D630 VR - DH630 VR
D630 LVR
Visible isolation switch
J630 VR**
Withdrawable rear connections
*include:
4 numbers*

1) Circuit breaker, fixed front connections, without release

N° P	D630 SD	DH630 SD	D630 L SD
3P	716030	716031	716032
4P	716040	716041	716042

2) Release

Release type: standard

In (A)	3P - 3D	4P - 3D	4P - 4D	4P - 3DN*	
400	716112	716132	716122	716142	
500	716111	716131	716121	716141	
630	716110	716130	716120	716140	

Release type: A

500	716211		716221		
630	716210		716220		

Release type: B

500	716261		716271		
630	716260		716270		

Release type: S

400	716162		716172		
500	716161		716171		
630	716160		716170		

 J unit ⁽¹⁾

All auxiliaries (possible installation: AS - ST - UV)

	716361	716371			
--	--------	--------	--	--	--

Lock (possible installation: AS only)

	716360	716370			
--	--------	--------	--	--	--

* Protected neutral 50%

(1) Switch J = D630 SD + J unit

3) Rear connections (1 set per pole)

726741	RBPCDAR
--------	---------

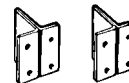
4) Visible isolation device

Locking in withdrawn position (lock not supplied)

VR 630

3 P	726553
4 P	726554

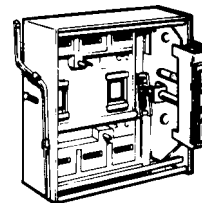

Visible isolation circuit breaker D630 V - DH630 V - D630 LV
Visible isolation switch J630 V
Withdrawable without connections
*include:
3 numbers*

1) Circuit breaker, fixed with front connections, without release

N° P	D630 SD	DH630 SD	D630 L SD
3P	716030	716031	716032
4P	716040	716041	716042

2) Release

Release type: standard

In (A)	3P - 3D	4P - 3D	4P - 4D	4P - 3DN*	
400	716112	716132	716122	716142	
500	716111	716131	716121	716141	
630	716110	716130	716120	716140	

Release type: A

500	716211		716221		
630	716210		716220		

Release type: B

500	716261		716271		
630	716260		716270		

Release type: S

400	716162		716172		
500	716161		716171		
630	716160		716170		

 J unit ⁽¹⁾

All auxiliaries (possible installation: AS - ST - UV)

	716361	716371			
--	--------	--------	--	--	--

Lock (possible installation: AS only)

	716360	716370			
--	--------	--------	--	--	--

* Protected neutral 50%

(1) Switch J = D630 SD + J unit

3) Visible isolation device

Locking on withdrawn position (lock not supplied)

V 630

3 P	726533
4 P	726534

If required:

Front connections (1 set per pole)

726732	RBPDAV
--------	--------

or

Rear connections (1 set per pole)

726741	RBPCDAR
--------	---------

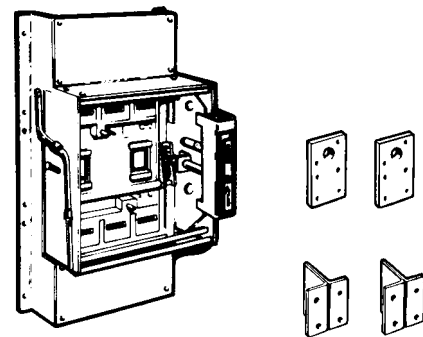
or
to order: D630 V without connections, with standard release

1 number
D630 V

In (A)	3P - 3D	4P - 4D	4P - 3DN*		
400	716662	716672	716692		
500	716661	716671	716691		
630	716660	716670	716690		

* Protected neutral 50%

If required add one set with front or rear connections per pole, number: see above.

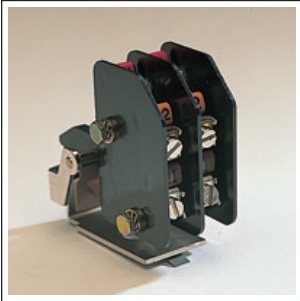
 Characteristics of circuit breakers: page A.4
 Characteristics of releases: page A.6
 Characteristics of auxiliaries: page A.18
 Dimensions: page A.111
 Connections: page A.129

Auxiliaries
Display contacts

726460	1 AS
726461	2 AS
726462	3AS
726468	1 BA

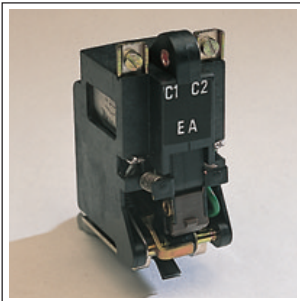
ST shunt trip release

AC 50, 60 Hz - DC

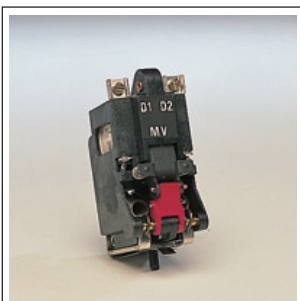
726401	24V
726402	48V
726403	110/127V
726405	220/250V
726407	380/415V
726408	440/500V

UV undervoltage release

AC 50 Hz

726431	24V
726432	48V
726433	110/127V
726435	220/240V
726437	380V
726436	415/440V
726438	500V

Characteristics of auxiliaries: page A.18

UV undervoltage release
(contd.)

AC 60 Hz

726451	24V
726452	48V
726453	110/127V
726455	220V
726457	380/440V
726458	500V

UV + time delay AC 50 Hz

726495	220V
726497	380V

DC

726441	24V
726442	48V
726443	110/125V
726446	250V

Electrical control

AC

725641	24V
725642	48V
725643	110/127V
725645	220/240V
725647	380V
725648	415V

DC

725651	24V
725652	48V
725653	110/125V
725655	220/250V

Locking of the control

In "OFF" position with lock Ronis 1104 (supplied)

726670

Rotary controls
Direct on the apparatus

725660	CRDG
--------	------

Grey handle

725661	CRDR
--------	------

Red handle

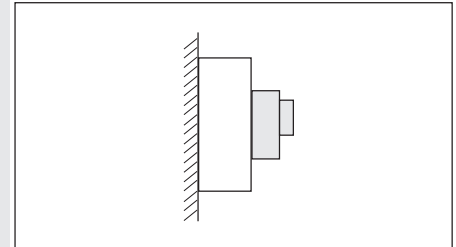

Behind door or panel

725680	CRDPG
--------	-------

Grey handle

725681	CRDPR
--------	-------

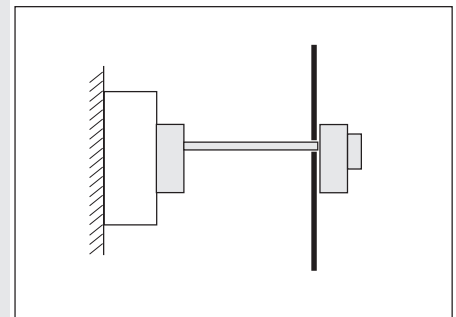
Red handle

Lock (Ronis 1104)

769080

Funnel

769090



Accessories

Locking control handle in "OFF" position

With removable unit for 3 padlocks (not supplied)

726900

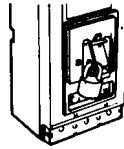

With device for 3 padlocks (not supplied) and/or Ronis type lock 1104, right opening or Profalux type KS 5B 20 D 4Y (lock not supplied)

726901

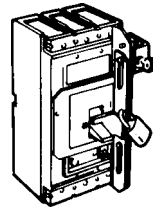

Terminal covers

One 4-pole terminal cover, sealable for fixed device with front connections

726784 4 P

Wiring isolation

Device allowing connection of 8 circuits.

Possible installation:

- 3 P: 2 devices
- 4 P: 3 devices

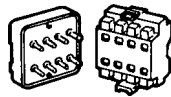

723760 Complete

723761 Fixed part
723762 Moving part

Rating protection

Device preventing insertion of a breaker with a different rating



726590

Door frame

725582

Ronis lock 1104

755960 Right opening

755961 Left opening

Components for withdrawable unit

Fixed part

DAV

726513 3 P

726514 4 P

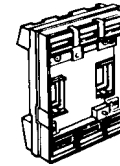

Moving part (pins)

726510 1 P

Installation

Fixed device

Panel mounting

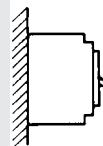

Mounting on section or bar with plate* for device with rear connections

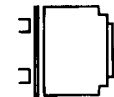

* intermediary

726824 3-4 P

Withdrawable device

Panel mounting

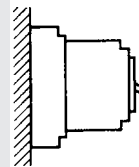

Mounting behind panel

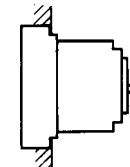

Mounting on section or bar

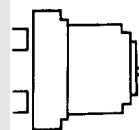

Connection (1 set per pole)

Fixed device

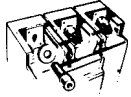

Front connections for bars or cables with lugs.
Width 40 mm, screw M12

Optional:

Extenders for bars or cables with lugs.
Width 40 mm, holes Ø 13 flat

on narrow edge

Rear connections for bars or cables with lugs.
Width 32 mm (400/500A), 40 mm (630 A), holes Ø 13 flat or on narrow edge (400/500A)

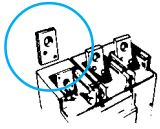

RBPFVAV
726712

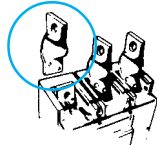

RBCFAV
726714

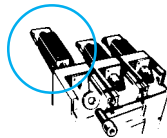

RBPCFAR
726723 400/500A
726733 630A

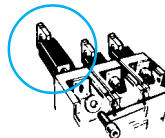

Terminals for cables without lugs
front connections

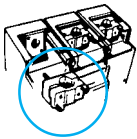

RC
726751 135 mm²
726752 300 mm²

rear connections

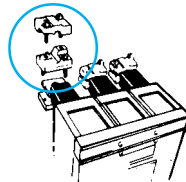

RC
726751 135 mm²
726752 300 mm²

Withdrawable device

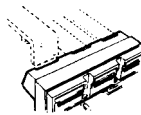
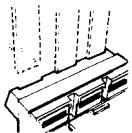

Rear of fixed part, sections for bars.
Width 40 mm, holes Ø 13

Optional:

Extenders for bars or cables with lugs - Width 40 mm, holes Ø 13
front extenders rear extenders

or on narrow edge

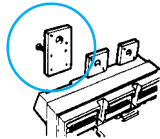

RBPDAV
726732

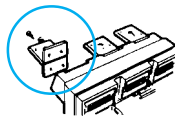

RBPCDAR
726741

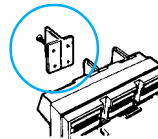

Terminals for cables without lugs
front connections

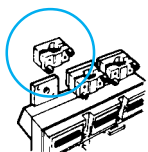

RC
726751 135 mm²
726752 300 mm²

rear connections

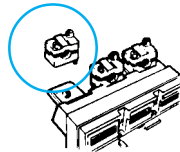

RC
726751 135 mm²
726752 300 mm²

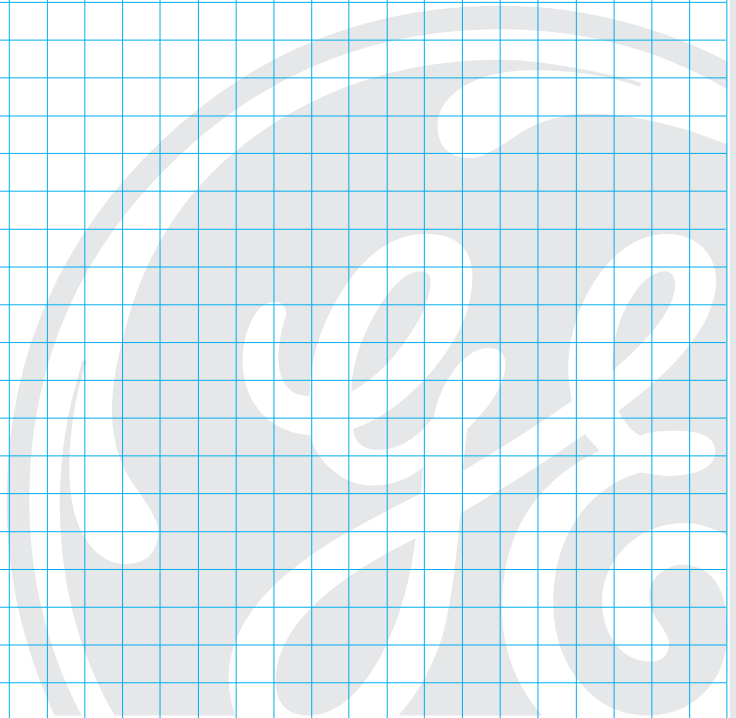

Notes

A large grid of blue lines on a white background, intended for taking notes. The grid covers most of the page area below the 'Notes' header.

**Circuit breaker D800 - DH800
Switch J800**
Fixed front connections

 include:
3 numbers

1) Circuit breaker, fixed front connections, without release

N° P	D800 SD	DH800 SD
3P	717030	717031
4P	717040	717041

2) Release

Release type: standard

In (A)	3P - 3D	4P - 3D	4P - 4D	4P - 3DN*	
630	716110	716130	716120	716140	
800	717110	717130	717120	717140	

Release type: A

630	716210		716220		
800	717210		717220		

Release type: B

630	716260		716270		
800	717260		717270		

Release type: S

630	716160		716170		
800	717160		717170		

 J unit ⁽¹⁾

All auxiliaries (possible installation: AS -ST - UV)

	717361	717371			
--	--------	--------	--	--	--

Verrou (possible installation: AS only)

	717360	717370			
--	--------	--------	--	--	--

* Protected neutral 50%

(1) Switch J = D800 SD + J unit

3) Front connections (1 set per pole)

727712	RBPFAV
--------	--------

or

to order: D800 FAV, DH800 FAV, with standard release

1 number

D800 FAV

In (A)	3P - 3D	4P - 4D	4P - 3DN*		
630	717711	717721	717741		
800	717710	717720	717740		

DH800 FAV

630	717761	717771	717791		
800	717760	717770	717790		

* Protected neutral 50%

 Characteristics of circuit breakers: page A.5
 Characteristics of releases: page A.7
 Characteristics of auxiliaries: page A.18
 Dimensions: page A.104
 Connections: page A.131



Fixed rear connections

include:
3 numbers



- 1) **Circuit breaker, fixed without release** (number: see page A.76)
- 2) **Release or J unit** (number: see page A.76)

3) **Rear connections** (1 set per pole)

727723	RBPFAR	
		

Withdrawable front connections

include:
3 numbers



- 1) **Circuit breaker, fixed without release** (number: see page A.76)
- 2) **Release or J unit** (number: see page A.76)

3) **Withdrawable unit**
ED

3 P	4 P
727503	727504

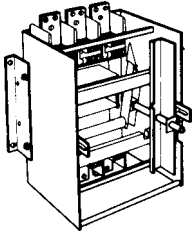

Characteristics of circuit breakers: page A.5
 Characteristics of releases: page A.7
 Characteristics of auxiliaries: page A.18
 Dimensions: page A.104
 Connections: page A.131

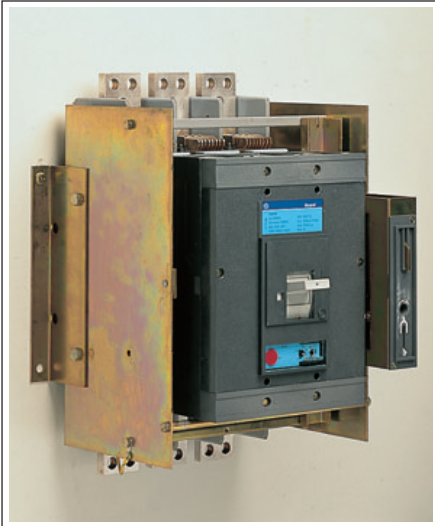
Visible isolation circuit breaker D800 V - DH800 V Visible isolation Switch J800 V
Withdrawable front connections
*include:
5 numbers*

1) Circuit breaker fixed, front connections, without release

N° P	D800 SD	DH800 SD
3P	717030	717031
4P	717040	717041

2) Release

Release type: standard

In (A)	3P - 3D	4P - 3D	4P - 4D	4P - 3DN*	
630	716110	716130	716120	716140	
800	717110	717130	717120	717140	

Release type: A

630	716210		716220		
800	717210		717220		

Release type: B

630	716260		716270		
800	717260		717270		

Release type: S

630	716160		716170		
800	717160		717170		

 J unit ⁽¹⁾

All auxiliaries (possible installation: AS - ST - UV)

	717361	717371			
--	--------	--------	--	--	--

Lock (possible installation: AS only)

	717360	717370			
--	--------	--------	--	--	--

* Protected neutral 50%

(1) Switch J = D800 SD + J unit

3) Withdrawable unit

ED

3 P	727503
4 P	727504

4) Isolating shutter

3 P	727595
4 P	727596

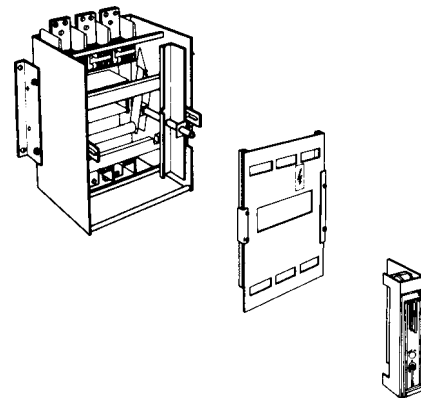
5) Locking device: door closed

728530	(Lock not supplied)
--------	---------------------

or

to order: D800 V front connection, with standard release
1 number

D800 V

In (A)	3P - 3D	4P - 4D	4P - 3DN*		
630	717661	717671	717691		
800	717660	717670	717690		

* Protected neutral 50%

 Characteristics of circuit breakers: page A.5
 Characteristics of releases: page A.7
 Characteristics of auxiliaries: page A.18
 Dimensions: page A.114
 Connections: page A.131

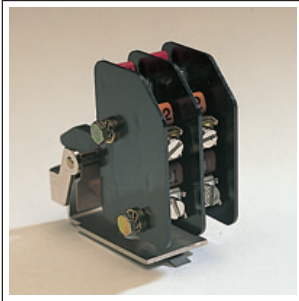
Auxiliaries
Display contacts

726460	1 AS
726461	2 AS
726462	3 AS
726468	1 BA

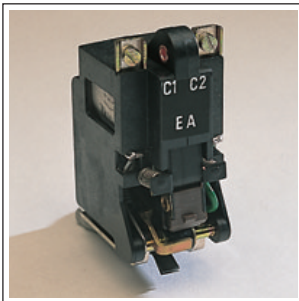
ST shunt trip release

AC 50, 60 Hz - DC

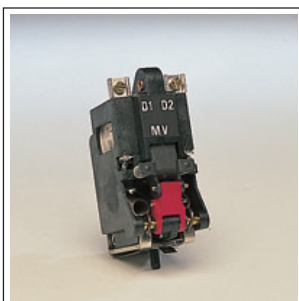
726401	24V
726402	48V
726403	110/127V
726405	220/250V
726407	380/415V
726408	440/500V

UV undervoltage release

AC 50 Hz

726431	24V
726432	48V
726433	110/127V
726435	220/240V
726437	380V
726436	415/440V
726438	500V

Characteristics of auxiliaries: page A.18

UV undervoltage release

(contd.)

AC 60 Hz

726451	24V
726452	48V
726453	110/127V
726455	220V
726457	380/440V
726458	500V

UV + time delay AC 50 Hz

726495	220V
726497	380V

DC

726441	24V
726442	48V
726443	110/125V
726446	250V

Electrical control

AC 50/60Hz

725641	24V
725642	48V
725643	110/127V
725645	220/240V
725647	380V
725648	415V

DC

725651	24V
725652	48V
725653	110/125V
725655	220/250V

Locking of the control

In "OFF" position with lock Ronis 1104 (supplied)

726670

Rotary controls
Direct on the apparatus

725660	CRDG
--------	------

Grey handle

725661	CRDR
--------	------

Red handle

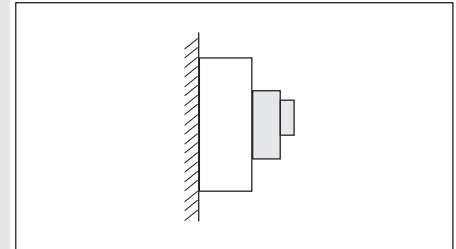

Behind door or panel

725680	CRDPG
--------	-------

Grey handle

725681	CRDPR
--------	-------

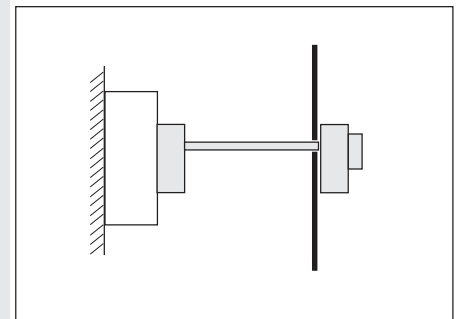
Red handle

Lock (Ronis 1104)

769080

Funnel

769090



Accessories

Locking the control handle in the "OFF" position

With removable unit for 3 padlocks
(not supplied)

726900

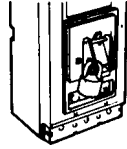

Using device for 3 padlocks
(not supplied)
and/or Ronis type lock 1104, 1/4 turn,
right opening or Profalux type
KS 5B 20 D 4Y

726901

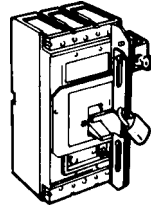

Locking in "removed" position, door open

727539 With lock (not supplied)

727531 With padlocks (not supplied)

Wiring isolation

Device enabling connection of
8 circuits.

Possible installation:

- 3 P: 2 devices

- 4 P: 3 devices

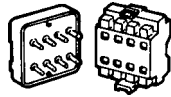

723760 Complete

723761 Fixed part

723762 Moving part

Rating error prevention

Device preventing insertion of a
breaker with a different rating



726590

Door frame

725582

Ronis 1104 lock

755960 Right opening

755961 Left opening

Components for withdrawable unit

Fixed part

DAV

727513 3 P

727514 4 P

Moving part (pins)

727593 3 P

727594 4 P

Isolating shutter

727595 3 P

727596 4 P

Contact position "plugged in"

728599

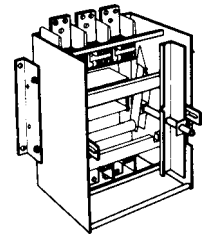

Installation

Fixed device

Panel mounting

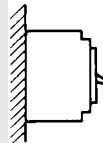

Mounting on section or bar
with plate* for device with rear
connections

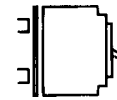

* intermediary

726824 3-4 P

Withdrawable device

Panel mounting

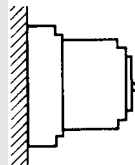

Mounting on section or
mounting frame

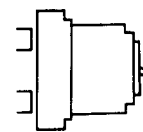

Connection (1 set per pole)

Fixed device

Front connections for bars or cables with lugs
width 50 mm,
holes \varnothing 13

RBPFVAV

727712

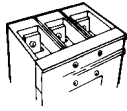

Optional:

Extenders for bars or cables with lugs.
Width 50 mm, holes \varnothing 13
on narrow edge

RBCFAV

727714

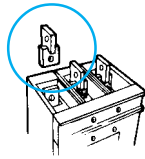

Rear connections for bars or cables with lugs.
Width 32 mm, holes \varnothing 13

RBPFAR

727723

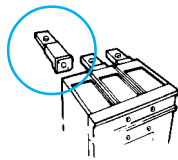

Withdrawable device

Rear of fixed part,
sections for bars.
Width 50 mm,
holes \varnothing 13

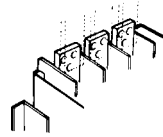

Optional:

Extenders for bars or cables with lugs
Width 50 mm, holes \varnothing 13
on narrow edge

RBCAV

728711

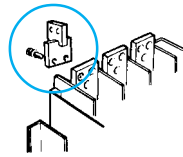

Rear connections for bars or cables with lugs
Width 50 mm, holes \varnothing 13

flat

RBPAR

728721

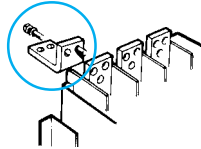

or on narrow edge

RBCAR

728722

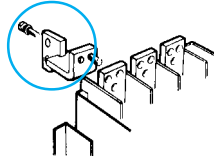

**Circuit breaker D1250
Switch J1250**
Fixed front connections
*include:
2 numbers*

1) Circuit breaker, fixed front connections, without release

N° P	D1250 SD
3P	718030
4P	718040

2) Release

Release type: standard

In (A)	3P - 3D	4P - 3DN*	4P - 4D		
800	718112	718142	718122		
1000	718111	718141	718121		
1250	718110	718140	718120		

Release type: A

1000	718211		718221		
1250	718210		718220		

Release type: B

1000	718261		718271		
1250	718260		718270		

Release type: S

800	718162	718192	718172		
1000	718161	718191	718171		
1250	718160	718190	718170		

 J unit ⁽¹⁾

All auxiliaries (possible installation: AS - ST - UV)

	718371		718371		
--	--------	--	--------	--	--

Lock (possible installation: AS only)

	718370		718370		
--	--------	--	--------	--	--

* Protected neutral 50%

or
to order: D1250 FAV, with standard release
1 number

In (A)	3P - 3D	4P - 4D	4P - 3DN*		
800	718712	718722	718742		
1000	718711	718721	718741		
1250	718710	718720	718740		

* Protected neutral 50%

 Characteristics of circuit breakers: page A.5
 Characteristics of releases: page A.7
 Characteristics of auxiliaries: page A.18
 Dimensions: page A.115
 Connections: page A.131

Withdrawable front connections

include:
3 numbers



**Visible isolation circuit breaker D1250 V
Visible isolation switch J1250 V**

Withdrawable front connections

include:
5 numbers



- 1) Circuit breaker, fixed without release (number: see above)
- 2) Release or J unit (number: see above)

3) Withdrawable unit
ED

3 P	4 P
728503	728504

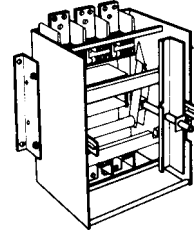

- 1) Circuit breaker fixed, without release (number: see page A.82)
- 2) Release or J unit (number: see page A.82)

3) Withdrawable unit
ED

3 P	728503
4 P	728504

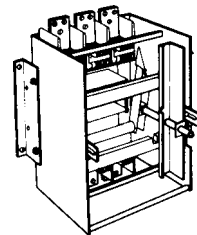

4) Isolating shutter

3 P	728595
4 P	728596

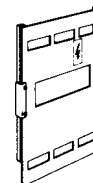

5) Locking device, door closed

728530	(Lock not supplied)
--------	---------------------



or
to order: D1250 V, with standard release

1 number

D1250 V

In (A)	3P - 3D	4P - 4D	4P - 3DN*		
800	718662	718672	718692		
1000	718661	718671	718691		
1250	718660	718670	718690		

* Protected neutral 50%

Characteristics of circuit breakers: page A.5
 Characteristics of releases: page A.7
 Characteristics of auxiliaries: page A.18
 Dimensions: page A.115
 Connections: page A.131

Auxiliaries
Display contacts

728460	1 AS
728461	2 AS
728462	3 AS
728468	1 BA

ST shunt trip release

AC 50, 60 Hz

728401	24V
728402	48V
728403	110/127V
728405	220/240V
728407	380/415V
728408	440/500V

DC

728411	24V
728412	48V
728413	110/125V
728416	250V

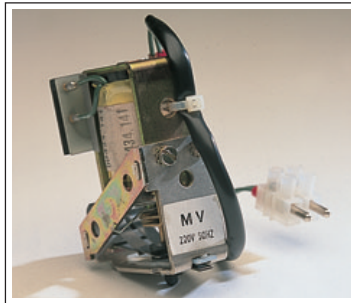
UV undervoltage release

AC 50, 60 Hz

728431	24V
728432	48V
728433	110V
728434	127V
728435	220V
728437	380V
728457	415V
728458	440V
728438	500V

UV + time delay AC 50 Hz

728495	220V
728497	380V

DC

728441	24V
728442	48V
728443	110V
728444	125V
728446	250V

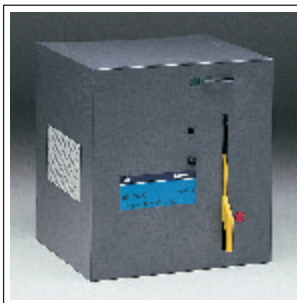
Electrical control

AC 50/60Hz

728630	24V
728631	48V
728632	110/127V
728633	220/240V
728634	380V
728635	415V

DC

728636	24V
728637	48V
728638	110/125V
728639	220/250V

Locking of the control

In "OFF" position with lock Ronis 1104 (supplied)

728670

Rotary controls
Direct on the apparatus

728660	CRDG
---------------	------

Grey handle

728661	CRDR
---------------	------

Red handle

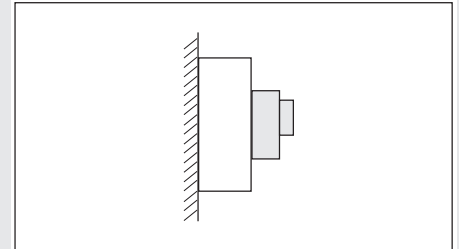

Behind door or panel

728680	CRDPG
---------------	-------

Grey handle

728681	CRDPR
---------------	-------

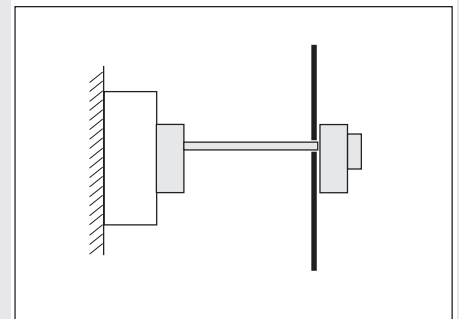
Red handle

Lock (Ronis 1104)

769080

Funnel

769090



Accessories

Locking control handle in "OFF" position

With device for 3 padlocks
(not supplied)
and/or Ronis type lock 1104, 1/4 turn,
right opening, or Profalux type
KS 5B 20 D 4Y

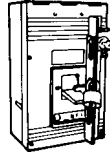

728901

Locking in "removed" position, door open

728539 With lock (not supplied)

728531 With padlocks (not supplied)

Wiring isolation

Device enabling connection of
8 circuits.
Possible installation:
3 devices

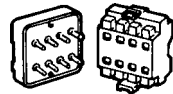

723760 Complete

723761 Fixed part
723762 Moving part

Rating error protection

Device preventing insertion of a
breaker with a different rating

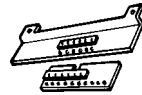

728590

Ronis 1104 lock

755960 Right opening

755961 Left opening

Components for withdrawable unit

Fixed part

728513 3 P
728514 4 P

Moving part

728593 3 P
728594 4 P

Isolating shutter

728595 3 P
728596 4 P

Wall cabinet

728597 3 P
728598 4 P

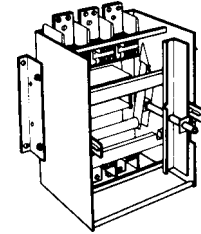

Contact position "plugged-in"

728599

Removal safety

728591

Installation

Fixed device

Panel mounting

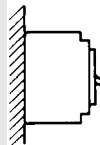

Withdrawable device

Panel mounting

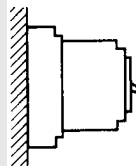

Mounting on section or bar

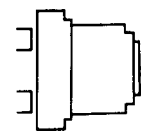

Connection (1 set per pole)
Fixed device

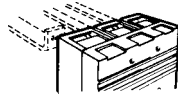
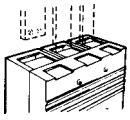

Front or rear, for bars
width 50 mm, screw M10

Optional:

Extenders for bars or cables with lugs.
Width 50 mm, holes \varnothing 13
flat

Rear connections for bars or cables with lugs.
Width 50 mm, holes \varnothing 13

on narrow edge

flat

on narrow edge

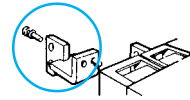
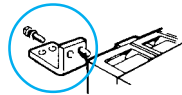
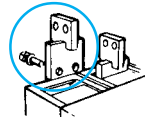
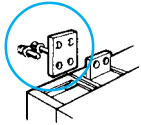

RBPVAV

RBCAV

RBPAR

RBCAR

728712

728711

728721

728722

Withdrawable

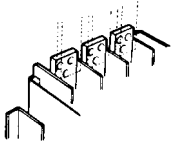

Front or rear, on fixed
part, sections for bars.
Width 50 mm,
holes \varnothing 13

Optional:

Extenders for bars
Width 50 mm, holes \varnothing 13
on narrow edge

Rear connections for bars
Width 50 mm, holes \varnothing 13

flat

on narrow edge

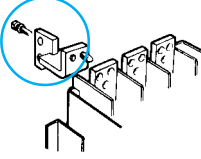
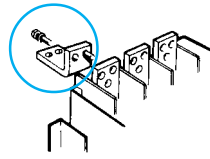
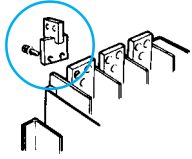

RBCAV

RBPAR

RBCAR

728711

728721

728722

Spreader for cables with lugs

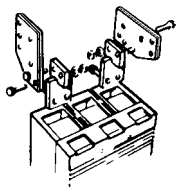

1 set: up- or downline,
complementary
for bars on narrow edge.
(connection front
or rear for fixed or
withdrawable device)

CRBC

728751 3P

728752 4P

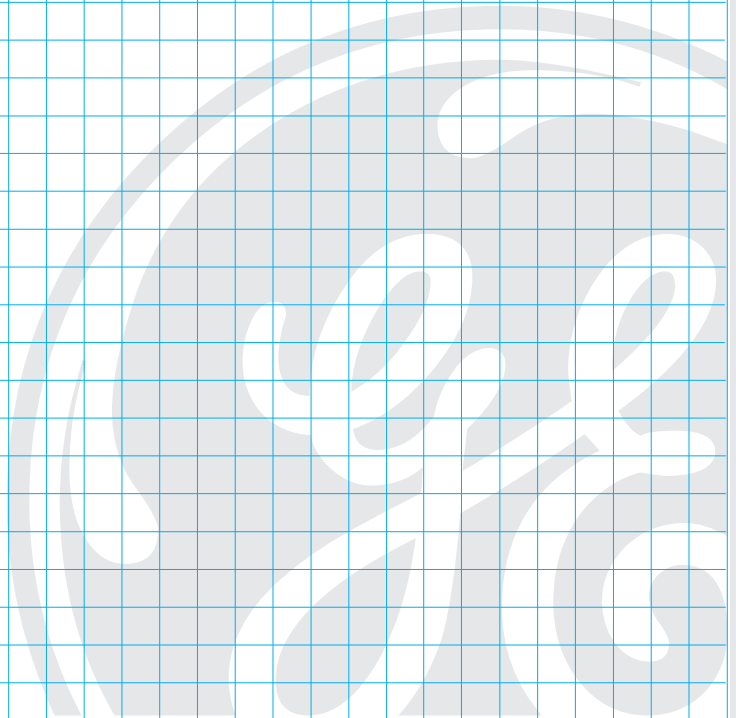

Notes

A large grid of blue lines on a white background, intended for taking notes. The grid covers most of the page area below the 'Notes' header.

Automatic changeover switches

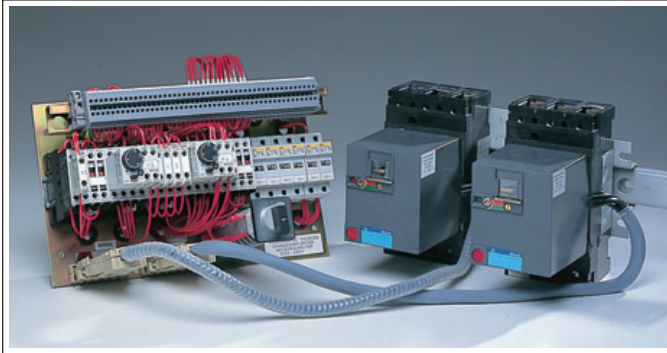

General

Automatic changeover switches enable you to ensure continuous power supply to a facility with minimum interrupt time, either from a normal source or from a replacement source, with automatic transfer from one source to another.

These are particularly suitable for industrial or tertiary facilities with a replacement source:

- which is either permanent:
 - . independent generator set
 - . mains
- or non-permanent:
 - . generator set which uses start and stop commands given by the source changeover switch.

Description

Automatic changeover devices are composed of:

- two circuit breakers or Record switches, which may be:
 - . identical, or
 - . different.

Each is equipped with an electric control with the auxiliary contacts necessary for operation and display ("ON/OFF" and "fault" contacts on free terminals).

- 1 support mounting plate equipped with mechanical locking.
- 1 automatic controller mounting plate which can be detached from the support mounting plate.
- The changeover devices have the same characteristics and capabilities for adaptation to circuits to be protected as their component units.

Installation

The automatic changeover devices are delivered wired and ready to connect.

They can be mounted:

- horizontally, or
- vertically.

Characteristics

Rated current In	160-250	400 to 1250
Nominal voltage	220-380V 50 Hz	220-380 V 50 Hz
Relay power supply voltage		
without auxiliary source	220-380V 50 Hz	220-380V 50 Hz
with auxiliary source	220-380V 50 Hz	220-380V 50 Hz
Maximum current drain		
opening	460 VA	260 VA
closing	460 VA	90 VA
permanent	18 VA	18 VA
Minimum changeover time		
normal → replacement	0.3 s (1)	0.3 s (1)
replacement → normal	0.3 s	0.3 s

(1) If necessary, add generator start-up time.

Structure

Rated current In	160	250	400	630	800	1250	
Composition	2 D160	2 D250 1 D250+ 1 D160	2 D400	2 D630 1 D630+ 1 D400	2 D800 1 D800+ 1 D630 1 D800 + 1D400	2 D1250	
Model	fixed	front connections	•	•	•	•	•
		rear connections	•	•	•	•	•
	withdrawable	front connections	•	•	•	•	-
		rear connections	•	•	•	•	-
Version	normal	D	•	•	•	•	•
	high breaking capacity	DH	•	•	•	•	-
	limiter	D...L	•	•	•	•	-
	switch	J	•	•	•	•	•
Releases	standard		•	•	•	•	•
	low magnetic	A	•	•	•	•	•
	selective	S	•	•	•	•	•
	magnetic only	B	•	•	•	•	•
Auxiliaries additional possible for automatic IDS Record DP	device at source	1 AS	1 AS	1 AS	3 AS or 1 ST	3 CA or 1 EA	1 CA
	device at source on replacement	2 AS or 1 ST	2 AS or 1 ST	2 AS or 1 ST	4 AS or 1 ST+1 AS	4 AS or 1 ST+1 AS	2 AS



Operation

The automatic controller mounting plate contains the relay equipment for:

- changing over the power supply of circuits from the normal source to the replacement source in case of loss of normal voltage
- changing over the power supply of circuits from the replacement source to the normal source once normal voltage returns
- giving load shedding and reload commands
- selecting the operating mode with a selector switch with the following positions:
 - OFF
 - automatic
 - operation on normal source
 - operation on replacement source

The automatic controller power is taken:

- either from the mains to be monitored
- or from the auxiliary source

Changeover is prevented when there is tripping due to a fault.

The unit is put back on automatic operation after tripping on fault and elimination of the fault by resetting the circuit breaker by using the emergency manual control.

Operating diagram

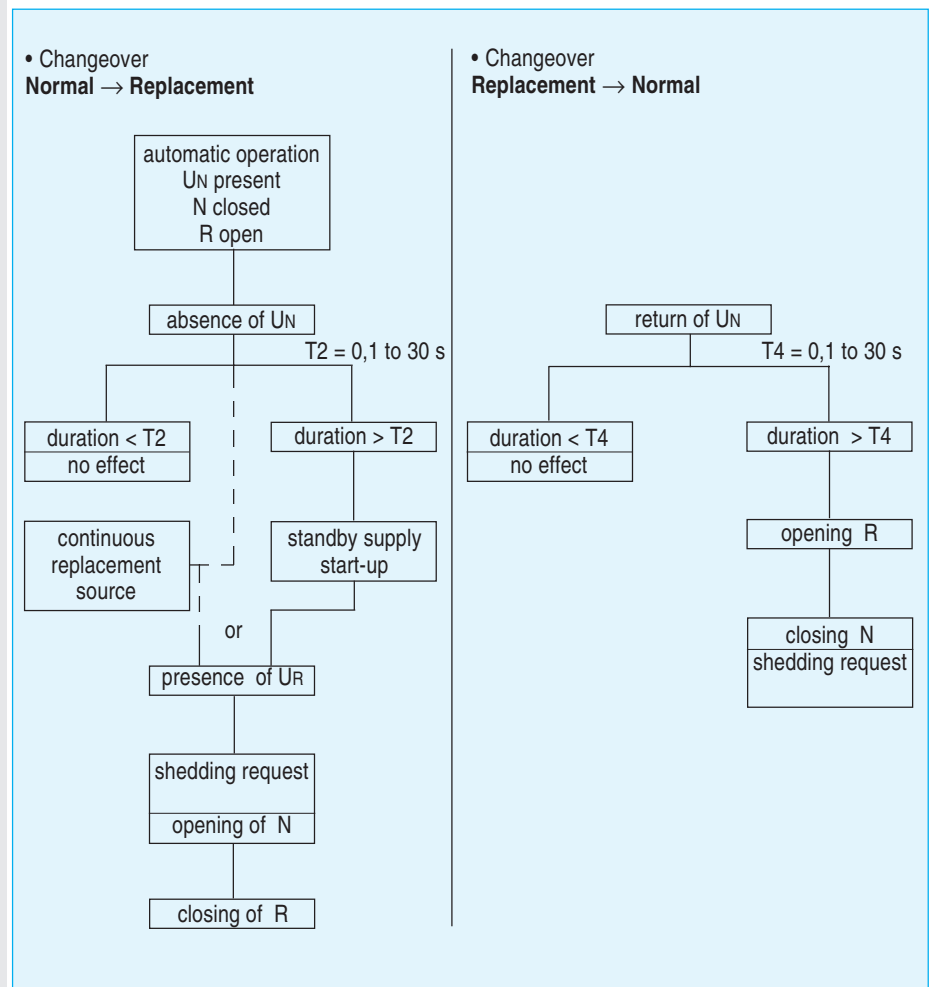

In withdrawable version the device **R** cannot be withdrawn without causing opening of device **N**.

T: time delay
 UN: normal voltage
 UR: replacement voltage
 N: unit on normal source
 R: unit on replacement source

Manual source changeover switches



Manual changeover devices are composed as follows:

- two Record circuit breakers or switches whose type, model, version and releases are identical to the automatic changeover switches.
- a support mounting plate holding the mechanical locking mechanism.

The units can receive auxiliaries, accessories, controls and locking devices within the capabilities of each of them.



Specification for automatic source changeover switches

Unit on normal source

- type: D ..., DH ..., D ... L, J ...
- number of poles
- releases: type: standard, A, B, S
number of poles
rated current I_n
- model: fixed with front or rear connections
withdrawable with front or rear connections (except 800 and 1250)
- electrical control: voltage
- auxiliary and fault contacts

Unit on replacement source

- type: D ..., DH ..., D ... L, J ...
- number of poles
- releases or J unit: type: standard, A, B, S
number of poles
rated current I_n
- model: identical to the unit on normal source
- electrical control: voltage
- auxiliary or fault contacts

Wiring connections

- one for unit on normal source
- one for unit on replacement source

Mechanical support and locking

- depending on model

Automatic controller

- voltage between phases: 220 or 380 V
connected between phases, three pole unit
connected between phases and neutral, four pole unit

Other options dependent on chosen device

- auxiliaries
- connections
- accessories
- locks

Specification for manual source changeover switches

Unit on normal source

- type: D ..., DH ..., D ... L, J ...
- number of poles
- releases or J unit: type: standard, A, B, S
number of poles
rated current I_n
- model: fixed with front or rear connections
withdrawable with front or rear connections (except 800 and 1250)

Unit on replacement source

- type: D ..., DH ..., D ... L, J ...
- number of poles
- releases: type: standard, A, B, S
number of poles
rated current I_n
- model: identical to unit on normal source

Support and mechanical locking

- depending on model

Other options dependent on the chosen device

- auxiliaries
- connections
- accessories
- locks
- connector on plug-in version



**Changeover switches D/DH/
J160 IDS**

include:
6 numbers

- 1) Circuit breaker or switch, fixed, for normal source
- 2) Circuit breaker or switch, fixed, for changeover source

D160 FAV

Release type: standard

In (A)	3P - 3D	4P - 3D	4P - 4D	4P - 3DN*	
25	713135	713155	713145	-	
40	713134	713154	713144	713164	
63	713133	713153	713143	713163	
100	713132	713152	713142	713162	
125	713131	713151	713141	713161	
160	713130	713150	713140	713160	

Release type: A

125	713431	713451	713441		
160	713430	713450	713440		

Release type: B

40	713934	-			
63	713933	-			
100	713932	-			
125	713931	713951			
160	713930	713950			

Release type: SM

100	713939				
125	713938				
160	713937				

Switch J160 FAV

160	713030	713040			
-----	--------	--------	--	--	--

or DH160 FAV

Release type: standard

25	713235	713255	713245	-	
40	713234	713254	713244	713264	
63	713233	713253	713243	713263	
100	713232	713252	713242	713262	
125	713231	713251	713241	713261	
160	713230	713250	713240	713260	

Release type: A

125	713411		713471		
160	713410		713470		

Release type: SM

100	713919				
125	713918				
160	713917				

* Protected neutral 50%

3) Electrical controls (1 per device) 723649

4) Wiring connection, device on normal source 723252
(3 AS + 1 BA included)

5) Wiring connection, device on replacement source 723253
(2 AS + 1 BA included)

6) Automatic controller 220V 50 Hz 723224
380V 50 Hz 723225

Characteristics of circuit breakers: page A.4
Characteristics of releases: page A.6
Characteristics of auxiliaries: page A.18
Dimensions: page A.124



Automatic changeover switches D/DH/J250 IDS

include:
6 numbers

- 1) Circuit breaker or switch, fixed, for normal source
- 2) Circuit breaker or switch, fixed, for replacement source

D250 FAV

Release type: standard

In (A)	3P - 3D	4P - 3D	4P - 4D	4P - 3DN*	
100	714134	714154	714144	-	
125	714133	714153	714143	-	
160	714132	714152	714142	714162	
200	714131	714151	714141	714161	
250	714130	714150	714140	714160	

Release type: A

200	714431		714441		
250	714430		714440		

Release type: B

200	714931	714951			
250	714930	714950			

Release type: SM

100	714939		714949		
200	714938		714948		
250	714937		714947		

Switch J250 FAV

250	714030	714040			
-----	--------	--------	--	--	--

or DH250 FAV

Release type: standard

125	714233	714253	714243	-	
160	714232	714252	714242	714262	
200	714231	714251	714241	714261	
250	714230	714250	714240	714260	

Release type: A

200	714411			714491	
250	714410			714490	

Release type: SM

160	714919		714979		
200	714918		714978		
250	714917		714977		

* Protected neutral 50%

3) Electrical controls (1 per device) 723649

4) Wiring connection, unit on normal source 723252
(3 AS + 1 BA included)

5) Wiring connection, unit on replacement source 723253
(2 AS + 1 BA included)

6) Automatic controller 220V 50 Hz 723224
380V 50 Hz 723225

Characteristics of circuit breakers: page A.4
Characteristics of releases: page A.6
Characteristics of auxiliaries: page A.18
Dimensions: page A.124



**Changeover switches
D/DH/J160 IDS - D/DH/J250 IDS**

Fixed front connections

Depending on model

1) to 6) Components and numbers: see previous pages

7) Mechanical support and locking

3 P	4 P
723200	723201

Fixed rear connections

1) to 6) Components and numbers: see previous pages

7) Mechanical support and locking

3 P	4 P
723200	723201

8) With rear connections (1 set per pole)
bars or cables with lugs

723721	D160
724721	D250

cables without lugs

723722	D160
724722	D250

Withdrawable front connections

1) to 6) Components and numbers: see previous pages

7) Mechanical support and locking

3 P	4 P	
723206	723207	D160 + D160
724206	724207	D250 + D250
724214	724215	D160 + D250

Withdrawable rear connections

1) to 6) Components and numbers: see previous pages

7) Mechanical support and locking

3 P	4 P	
723208	723209	D160 + D160
724208	724209	D250 + D250
724216	724217	D160 + D250

**Manual changeover switches
D/DH/J160 IDS - D/DH/J250 IDS**

include:
3 numbers

Characteristics of circuit breakers: page A.4
Characteristics of releases: page A.6
Characteristics of auxiliaries: page A.18
Dimensions: page A.124

1) Circuit breaker, fixed or switch for normal source (number: see pages A.93-94)

2) Circuit breaker, fixed or switch for replacement source
(number: see pages A.93-94)

3) Mechanical support and locking (number: see above, depending on model 7)

- fixed front connections
- fixed rear connections (add item 8)
- withdrawable front connections
- withdrawable rear connections

If required:

- auxiliaries, accessories, controls, locks
- 500 mm long wiring isolation with 6-wire connectors

725250



Automatic changeover switches D/DH/DL/J400 IDS

include:
11 numbers

- 1) Circuit breaker without release for normal source
- 2) Circuit breaker without release for replacement source

Fixed unit

	D400	DH400	D400 L
3 P	715033	715034	715035
4 P	715043	715044	715045

Withdrawable unit

3 P	715036	715037	715038
4 P	715046	715047	715048

- 3) Release for normal source
- 4) Release for replacement source

Release type: standard

In (A)	3P - 3D	4P - 3D	4P - 4D	4P - 3DN*
250	715112	715132	715122	715142
320	715111	715131	715121	715141
400	715110	715130	715120	715140

Release type: A

320	715211	715231	715221	715241
400	715210	715230	715220	715240

Release type: B

320	715261	715281		
400	715260	715280		

Release type: S

250	715162	-	715172
320	715161	715181	715171
400	715160	715180	715170

J unit ⁽¹⁾

All auxiliaries (possible installation: AS - ST - UV)

	715361	715371		
--	--------	--------	--	--

Lock (possible installation: AS only)

	715360	715370		
--	--------	--------	--	--

* Protected neutral 50%

(1) Switch J = D400 SD + J unit

5) Electrical controls (1 per unit)	725645
6) Auxiliary contacts for unit on normal source	726460 + 726461
7) Auxiliary contacts for unit on replacement source	726461
8) Fault tripping contact (1 per unit except J400)	726468
9) Wiring connections, unit on normal source	725251
10) Wiring connections, unit on replacement source	725252
11) Automatic controller	220V 50 Hz 380V 50 Hz 725220 725221

Characteristics of circuit breakers: page A.5
 Characteristics of releases: page A.7
 Characteristics of auxiliaries: page A.18
 Dimensions: page A.126



Automatic changeover switches
D/DH/DL/J630 IDS

include:
11 numbers

- 1) Circuit breaker without release for normal source
- 2) Circuit breaker without release for replacement source

Fixed unit

	D630	DH630	D630 L
3 P	716033	716034	716035
4 P	716043	716044	716045

Withdrawable unit

3 P	716036	716037	716038
4 P	716046	716047	716048

- 3) Release for normal source
- 4) Release for replacement source

Release type: standard

In (A)	3P - 3D	4P - 3D	4P - 4D	4P - 3DN*	
400	716112	716132	716122	716142	
500	716111	716131	716121	716141	
630	716110	716130	716120	716140	

Release type: A

500	716211		716221		
630	716210		716220		

Release type: B

500	716261		716271		
630	716260		716270		

Release type: S

400	716162		716172		
500	716161		716171		
630	716160		716170		

J unit ⁽¹⁾

All auxiliaries (possible installation: AS - ST - UV)

	716361	716371			
--	--------	--------	--	--	--

Lock (possible installation: AS only)

	716360	716370			
--	--------	--------	--	--	--

* Protected neutral 50%

(1) Switch J = D630 SD + J unit

- 5) Electrical controls (1 per unit) 725645
- 6) Auxiliary contacts for unit on normal source 726462
- 7) Auxiliary contacts for unit on replacement source 726461
- 8) Fault tripping contact (1 per unit except J630) 726468
- 9) Wiring connections, unit on normal source 725251
- 10) Wiring connections, unit on replacement source 725252
- 11) Automatic controls 725220
220V 50 Hz
380V 50 Hz 725221

Characteristics of circuit breakers: page A.5
 Characteristics of releases: page A.7
 Characteristics of auxiliaries: page A.18
 Dimensions: page A.126



Automatic changeover switches D/DH/J800 IDS

include:
11 numbers

- 1) Circuit breaker without release for normal source
- 2) Circuit breaker without release for replacement source

Fixed unit

	D800	DH800
3 P	717033	717034
4 P	717043	717044

- 3) Release for normal source
- 4) Release for replacement source

Release type: standard

In (A)	3P - 3D	4P - 3D	4P - 4D	4P - 3DN*	
630	716110	716130	716120	716140	
800	717110	717130	717120	717140	

Release type: A

630	716210		716220		
800	717210		717220		

Release type: B

630	716260		716270		
800	717260		717270		

Release type: S

630	716160		716170		
800	717160		717170		

J unit ⁽¹⁾

All auxiliaries (possible installation: AS - ST - UV)

	717361	717371			
--	--------	--------	--	--	--

Lock (possible installation: AS only)

	717360	717370			
--	--------	--------	--	--	--

* Protected neutral 50%

(1) Switch J = D800 SD + J unit

- 5) Electrical controls (1 per unit) 725645
- 6) Auxiliary contacts for unit on normal source 726462
- 7) Auxiliary contacts for unit on replacement source 726461
- 8) Fault tripping contact (1 per unit except J800) 726468
- 9) Wiring connections, unit on normal source 725251
- 10) Wiring connections, unit on replacement source 725252
- 11) Automatic controller 725220

220V 50 Hz
725221

380V 50 Hz

Characteristics of circuit breakers: page A.5
 Characteristics of releases: page A.7
 Characteristics of auxiliaries: page A.18
 Dimensions: page A.126



**Automatic changeover
D/DH/D... L/J 400-630 IDS
D/DH/J 800 IDS**

Fixed front connections

Depending on model

1) to 11) Components and numbers: see previous pages

12) Support and mechanical locking

3 P	4 P	
725200	725200	D400 + D400
726200	726200	D630 + D630
726202	726203	D630 + D400
726200	726200	D800 + D800
726200	726200	D800 + D630
726202	726203	D800 + D400

Fixed rear connections

1) to 11) Components and numbers: see previous pages

7) Support and mechanical locking: number: see above (IDS fixed front connections)

8) With rear connections (1 set per pole)

725723	D400
726723	D630 ≤ 500A
726733	D630 630A
727723	D800

Withdrawable front and rear connections

1) to 11) Components and numbers: see previous pages

12) Support and mechanical locking

3 P	4 P	
725202	725203	D400 + D400
726205	726206	D630 + D630
726208	726209	D630 + D400

Connection: on fixed part sections

if required:

13) Connection (1 set per pole)

front

725732	D400
726732	D630

rear

725741	D400
726741	D630

**Manual changeover switches
D/DH/D... L/J 400-630 IDS
D/DH/J 800 IDS**

include:
5 numbers

1) Circuit breaker without release for normal source,

2) Circuit breaker without release for replacement source,

3) Release or J unit for circuit breaker on normal source,

4) Release or J unit for circuit breaker on replacement source
number: see previous pages.

5) Support and mechanical locking (number: see above, according to model 12)

- fixed front connections
- fixed rear connections (add item 12)
- withdrawable:
 - . connection on fixed part sections
 - . front or rear connections (add item 13)

if required:

- auxiliaries, accessories, controls, locks
- wiring isolation with 6-wire connectors

725250

Characteristics of circuit breakers: page A.5
Characteristics of releases: page A.7
Characteristics of auxiliaries: page A.18
Dimensions: page A.126



Automatic changeover switches D/J1250 IDS fixed

include:
12 numbers

- 1) Circuit breaker, fixed without release for normal source
- 2) Circuit breaker, fixed without release for replacement source

	D1250
--	-------

3 P	718035
4 P	718045

- 3) Release for normal source
- 4) Release for replacement source

Release type: standard

In (A)	3P - 3D	4P - 3DN*	4P - 4D		
800	718112	718142	718122		
1000	718111	718141	718121		
1250	718110	718140	718120		

Release type: A

1000	718211		718221		
1250	718210		718220		

Release type: B

1000	718261		718271		
1250	718260		718270		

Release type: S

800	718162	718192	718172		
1000	718161	718191	718171		
1250	718160	718190	718170		

J unit ⁽¹⁾

All auxiliaries (possible installation: AS - ST - UV)

	718371		718371		
--	--------	--	--------	--	--

Lock (possible installation: AS only)

	718370		718370		
--	--------	--	--------	--	--

* Protected neutral 50%

- 5) Electrical controls (1 per unit) 728633
- 6) Auxiliary contacts for unit on normal source 728462
- 7) Auxiliary contacts for unit on replacement source 728461
- 8) Fault tripping contact (1 per unit) 728468
- 9) Wiring connections, unit on normal source 725251
- 10) Wiring connections, unit on replacement source 725252
- 11) Automatic controller 220V 50 Hz 725220
380V 50 Hz 725221
- 12) Support and mechanical locking 3 P 728202
4 P 728203

Connection: rear, on front sections

if required:

13) Sockets (1 set per pole)		Front	Rear
	Flat bar	728712	728721
	Narrow edge bar	728711	728722

Characteristics of circuit breakers: page A.5
 Characteristics of releases: page A.7
 Characteristics of auxiliaries: page A.18
 Dimensions: page A.126



Manual changeover switches D/J1250 IDS

include:
5 numbers

- 1) Circuit breaker without release for normal source,
- 2) Circuit breaker without release for replacement source,
- 3) Release or J unit for circuit breaker on normal source,
- 4) Release or J unit for circuit breaker on replacement source
number: see previous pages.

5) Support and mechanical locking

3 P	728200
4 P	728201

If required:
- auxiliaries, accessories, controls, locks

Connection: rear, on front sections

- If required:
- 6) With front or rear connections (1 set per pole)
- bar, flat or narrow edge, number: see above (add item 13)

Characteristics of circuit breakers: page A.5
 Characteristics of releases: page A.7
 Characteristics of auxiliaries: page A.18
 Dimensions: page A.126



Residual current earth leakage devices SHR 1100 - SHR 1110

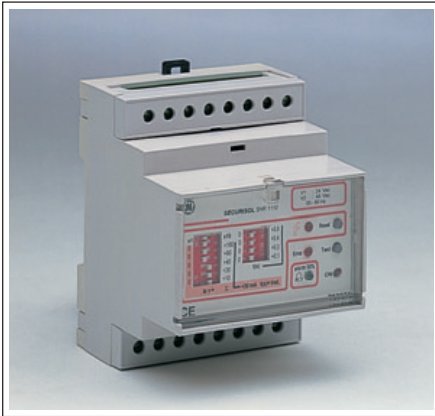

SHR 1100 (instantaneous)

797070	24-48V AC
797071	110-480V AC
797072	220/415V AC

SHR 1110 (time delayed)

797073	24-48V AC
797074	110-480V AC
797075	220/415V AC

Installation kit

797106

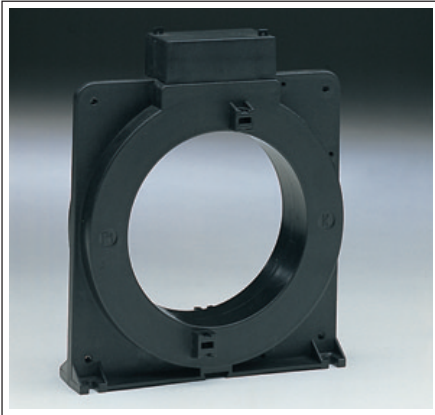

Detection cores

Closed core CITF

797060	CITF Ø 35
797061	CITF Ø 80
797062	CITF Ø 110
797063	CITF Ø 140
797064	CITF Ø 210

Open core CITO

797065	CITO Ø 65
797066	CITO Ø 104

Characteristics: page A.15-16
Connection diagram A.15-16

MTS earth leakage protection unit with separate core

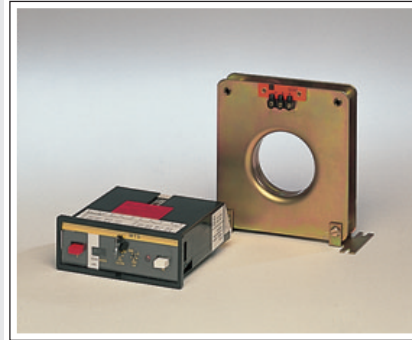

220/240V	380/415V	Inner core diameter
742010	742110	34Ø
742011	742111	55Ø
742012	742112	70Ø
742013	742113	100Ø

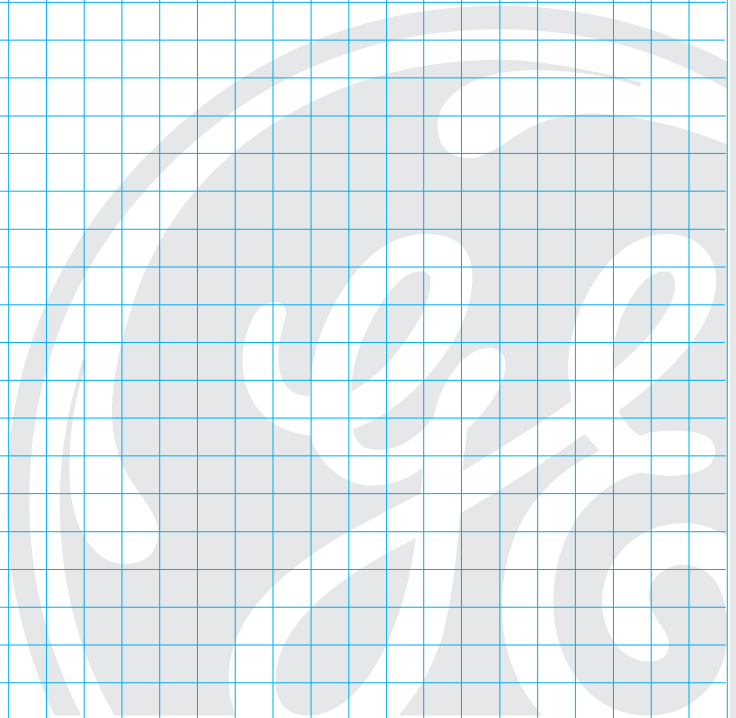

Notes

A large grid of blue lines on a white background, intended for taking notes. The grid covers most of the page area below the 'Notes' header.

Circuit breakers D125

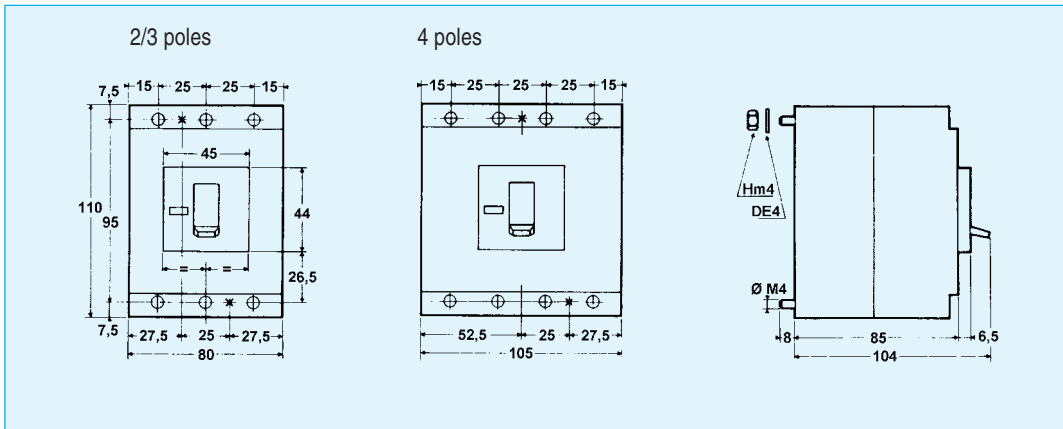

Circuit breakers D125 L

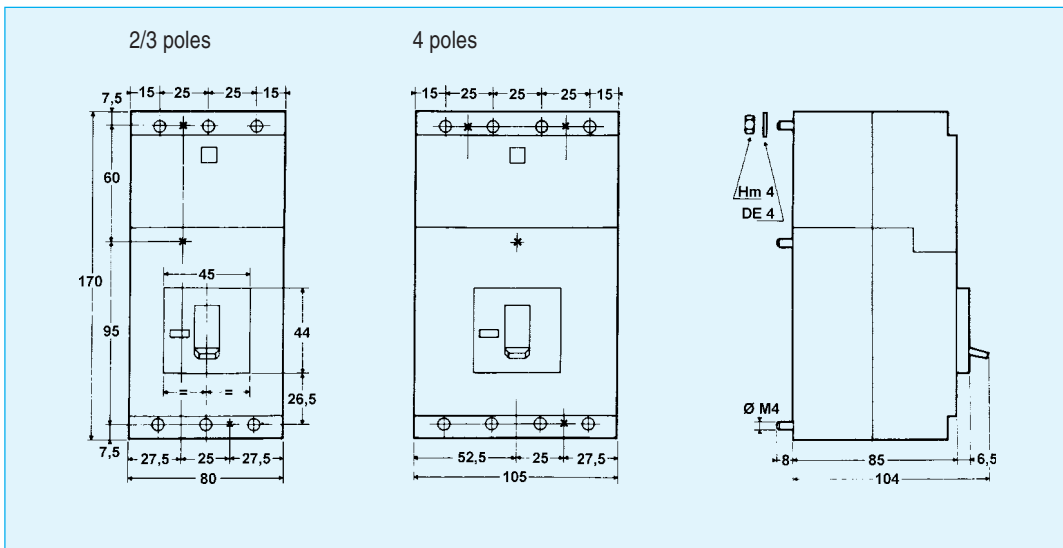

Circuit breakers D125 M

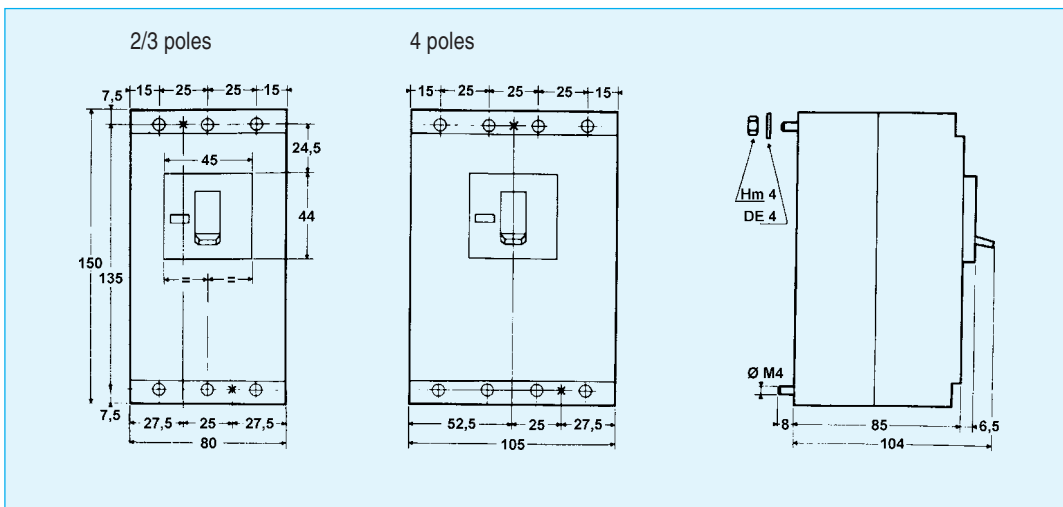

* : Fixation points
screw M4



Circuit breakers D160 - DH160 - D250 - DH250

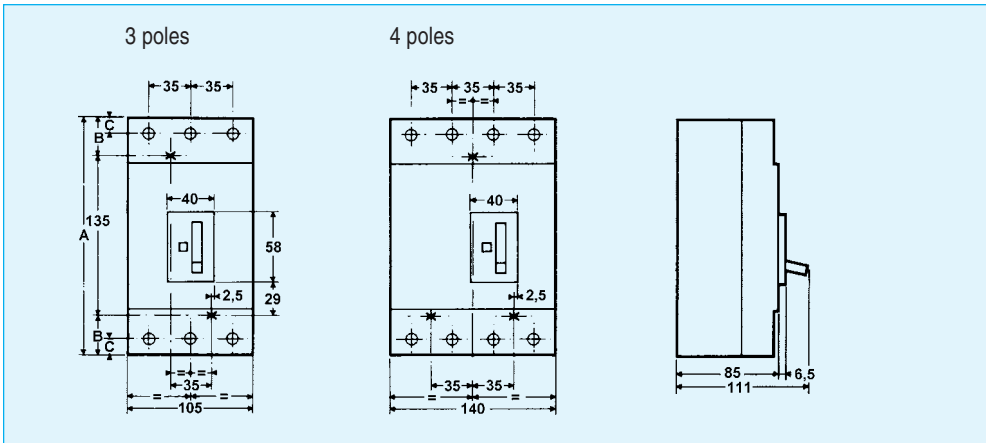

	160	250
A	160	200
B	12,5	32,5
C	12,5	14



Circuit breakers D160 L - D250 L

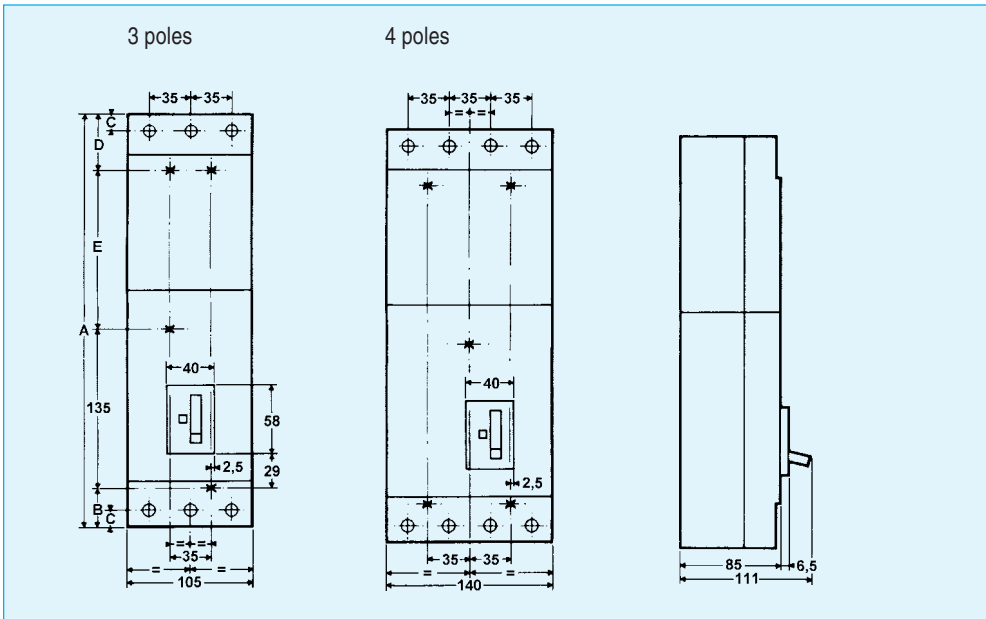

	160	250
A	275	350
B	12,5	32,5
C	12,5	14
D	12,5	47,5
E	115	135



Circuit breakers D160 M - DH160 M - D250 M - DH250 M

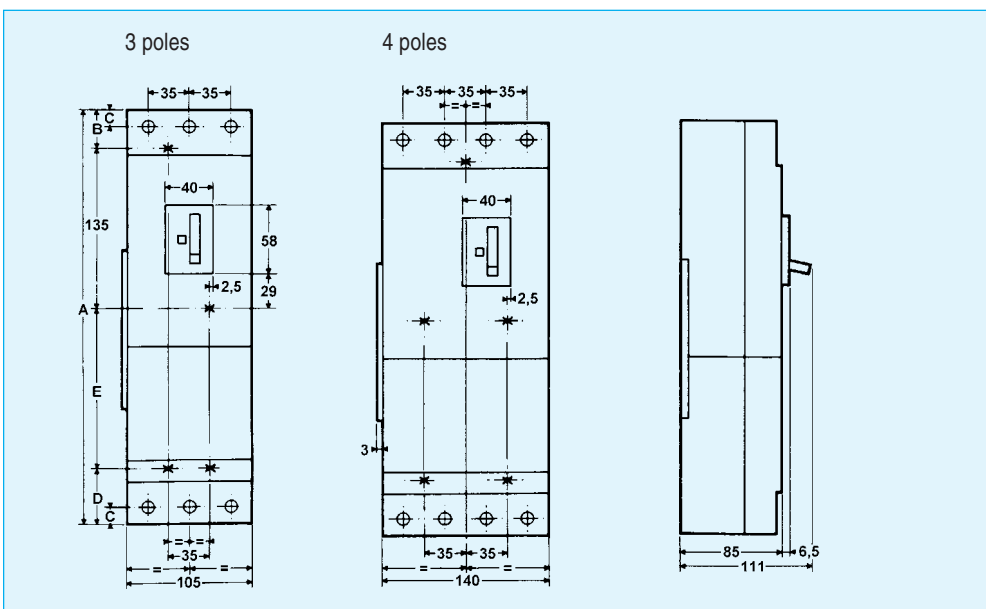

	160	250
A	275	350
B	12,5	32,5
C	12,5	14
D	12,5	47,5
E	115	135

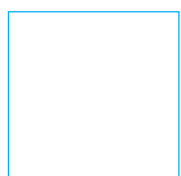

* : Fixation points screw M5



Circuit breakers D400 - DH400 - D400 L - D630 - DH630 - D630 L - D800 - DH800

A
104

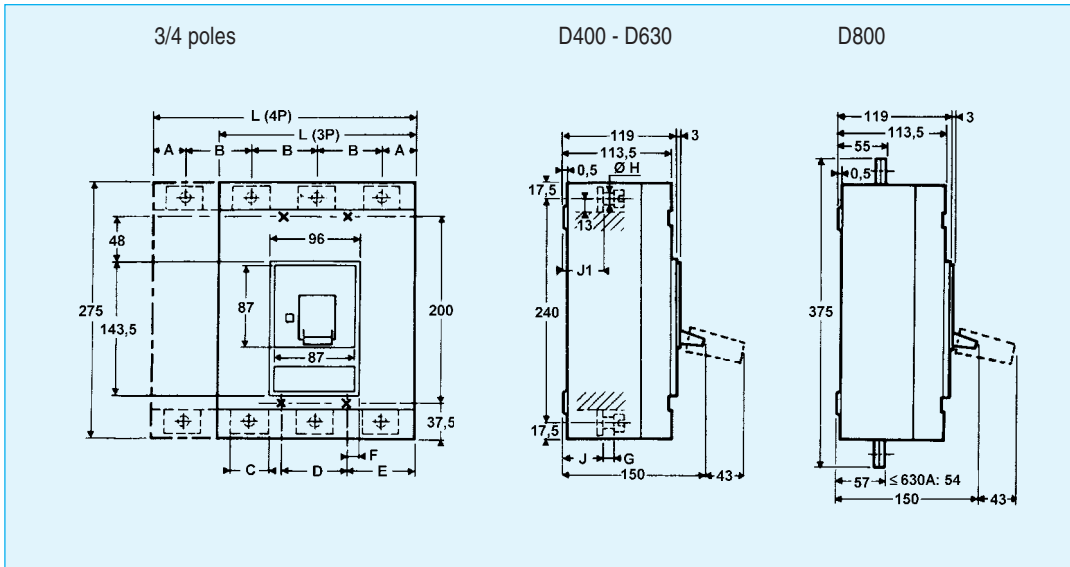

	400	630	800
A	25	35	35
B	45	70	70
C	32	40	-
D 3p	45	70	70
D 4p	90	70	70
E	47,5	70	70
F	25	13	13
G	11	12	-
H	10	12	-
J	38	44	-
J1	35,5	41	-
Ø K	5	6	6
L 3p	140	210	210
L 4p	185	280	280
M	-	190	200
N	-	60	65
P	-	225	244
R	-	10	28
S	-	12,5	22
T	-	260	270

Drilling diagrams for circuit breakers with rear connections

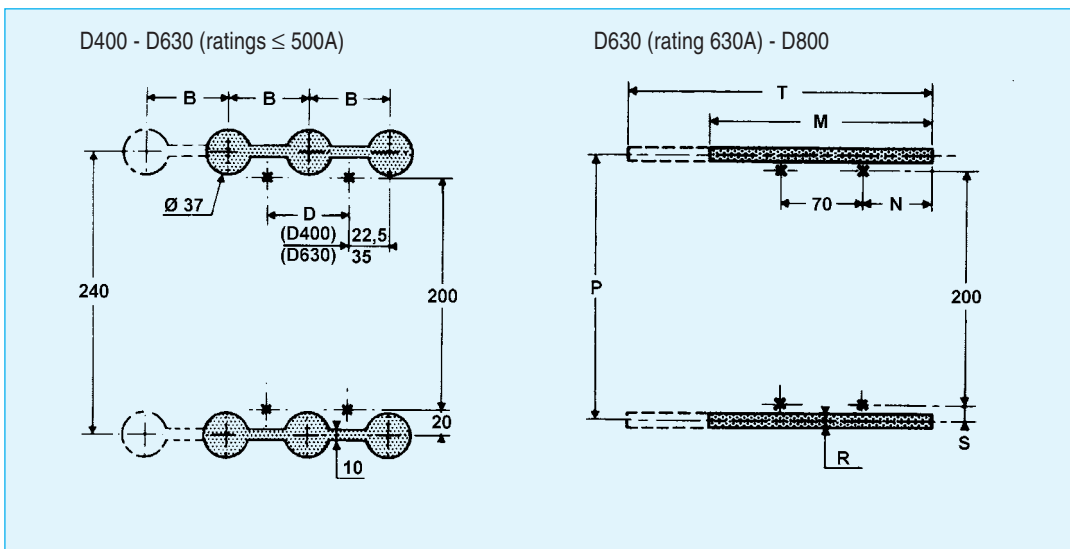

* : Fixation points
screw M Ø K



Circuit breakers D400 M - D630 M

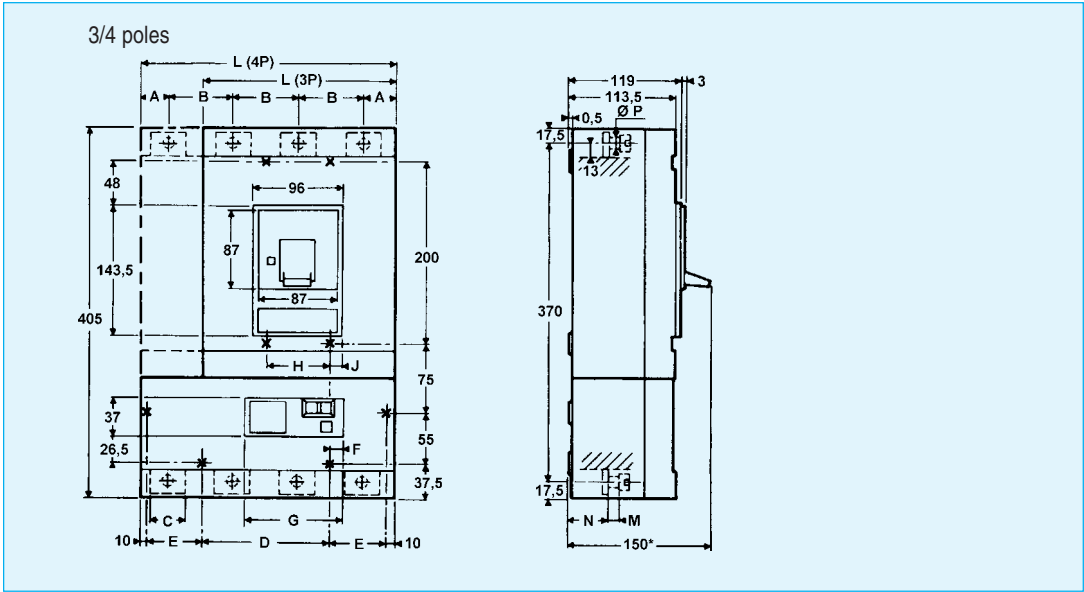

	400	630
A	25	35
B	45	70
C	32	40
D	90	140
E	37,5	60
F	25,5	15
G	96	100
H 3p	45	70
H 4p	90	70
J	25,5	13
Ø K	5	6
L 3p	185	280
L 4p	185	280
M	11	12
N	35,5	41
P	10	12
R	29	29,5
S	5	6
T	43	50
U	22	30
V	12,5	14

Earth leakage units M400 - M630

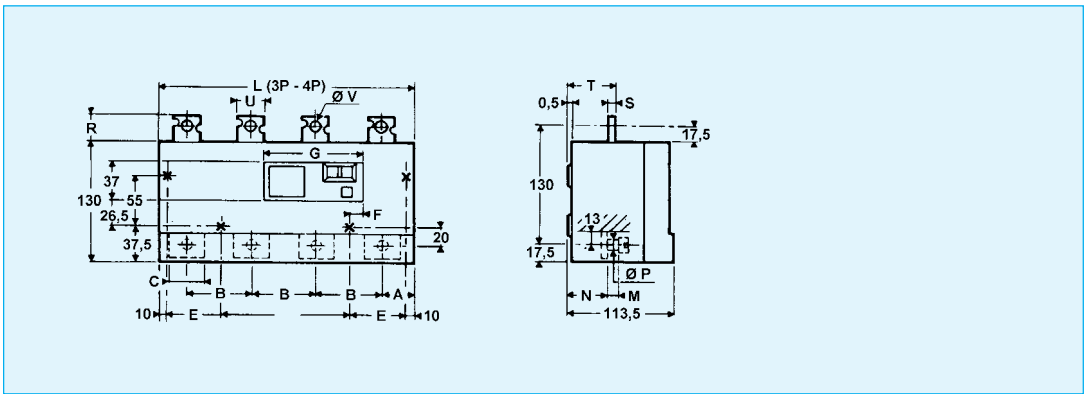

* : Fixation points
screw M Ø K
* : + 43 with extension

Circuit breakers D1250

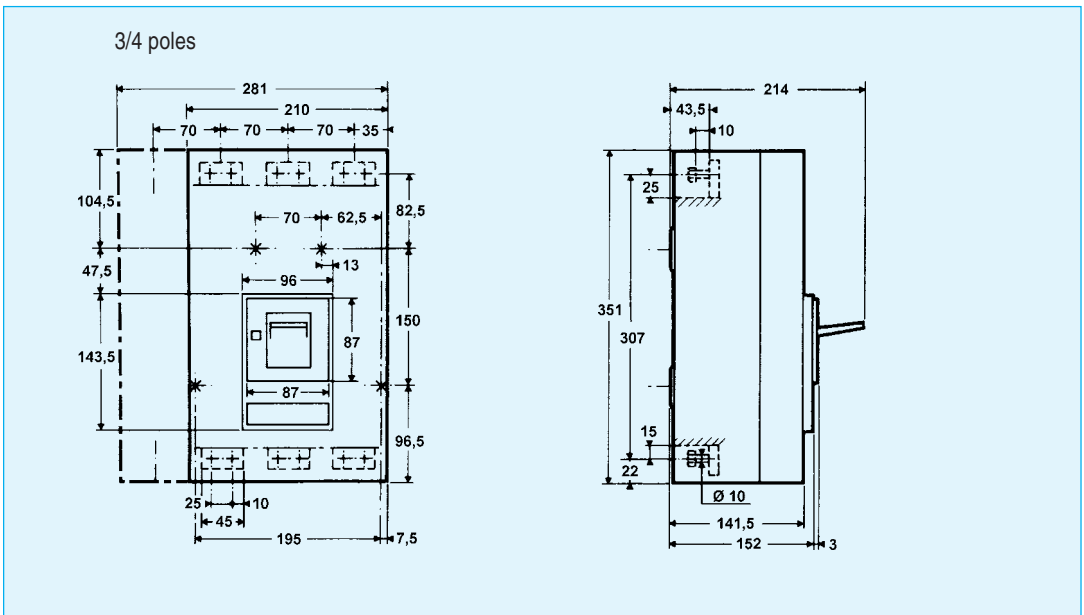

* : Fixation points
holes Ø 9

Withdrawable circuit breakers D125

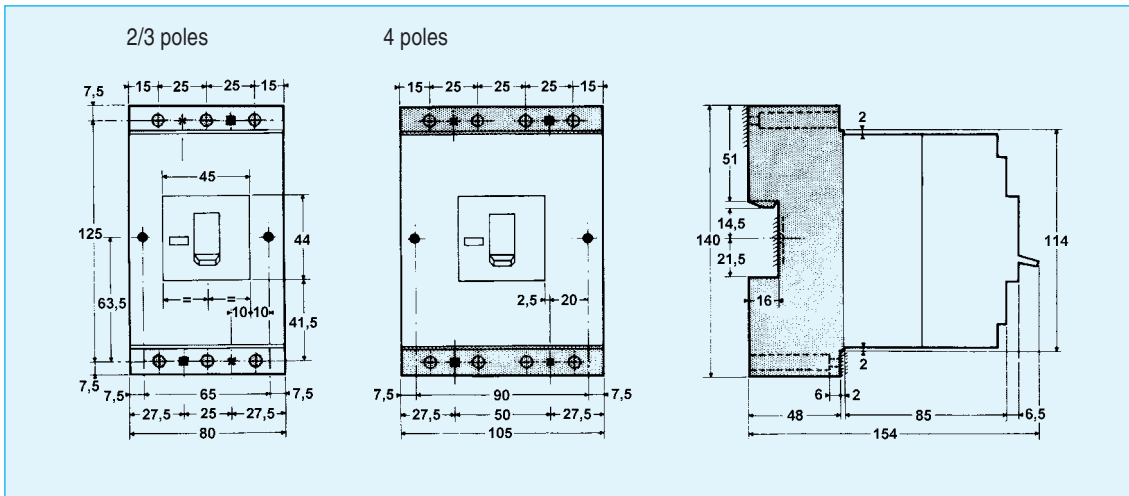

Withdrawable circuit breakers D125 L

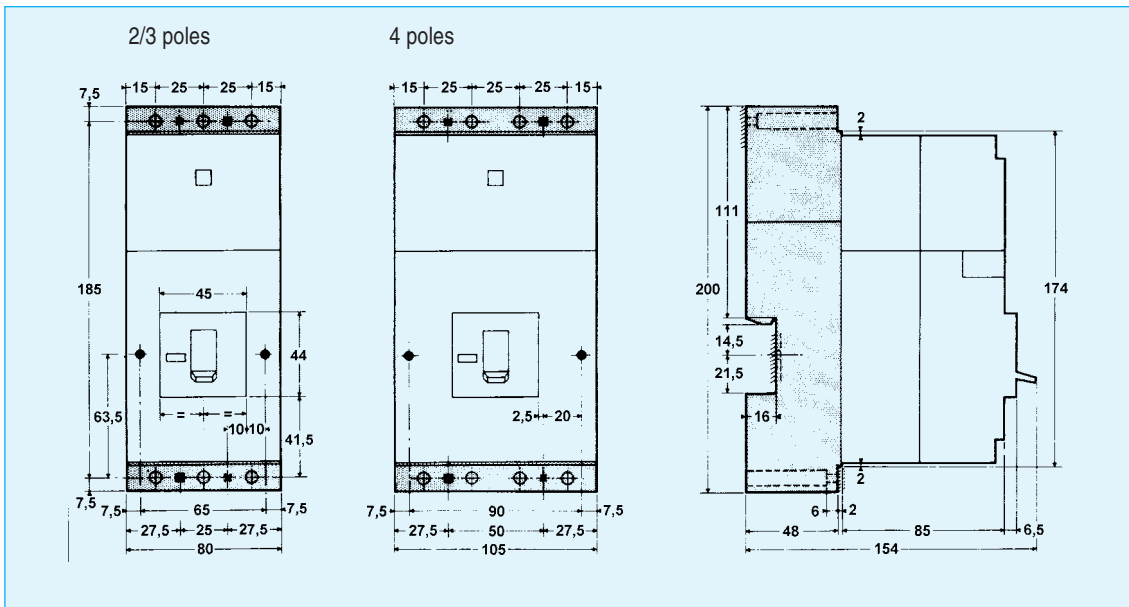

Withdrawable circuit breakers D125 M

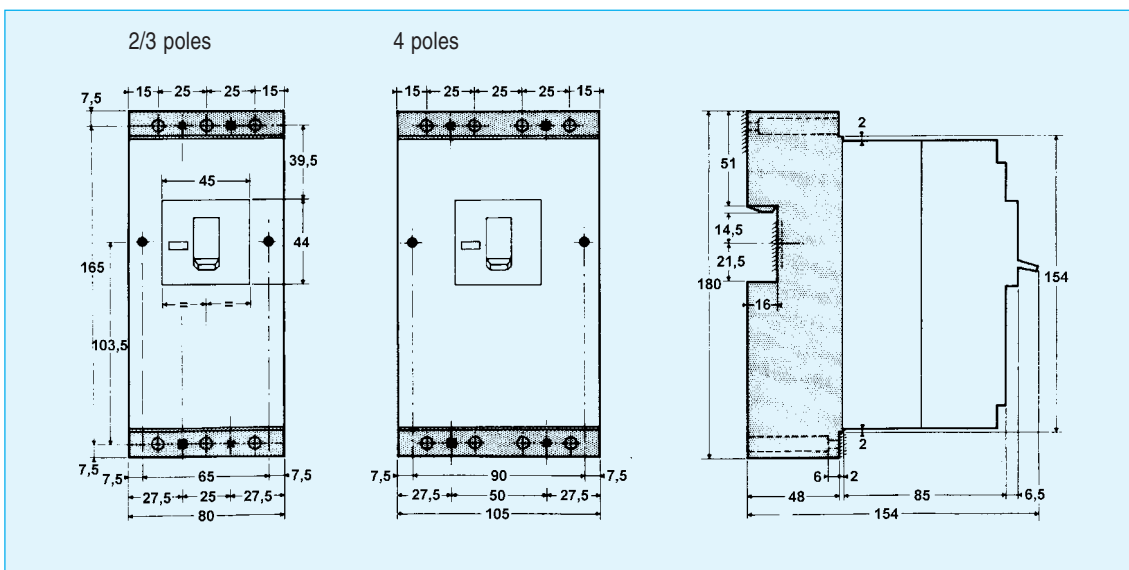

Two fixation points $\varnothing 4,2$ for mounting :

- * : on panel
- : behind panel
- : on section



Withdrawable circuit breakers D160 - DH160 - D250 - DH250

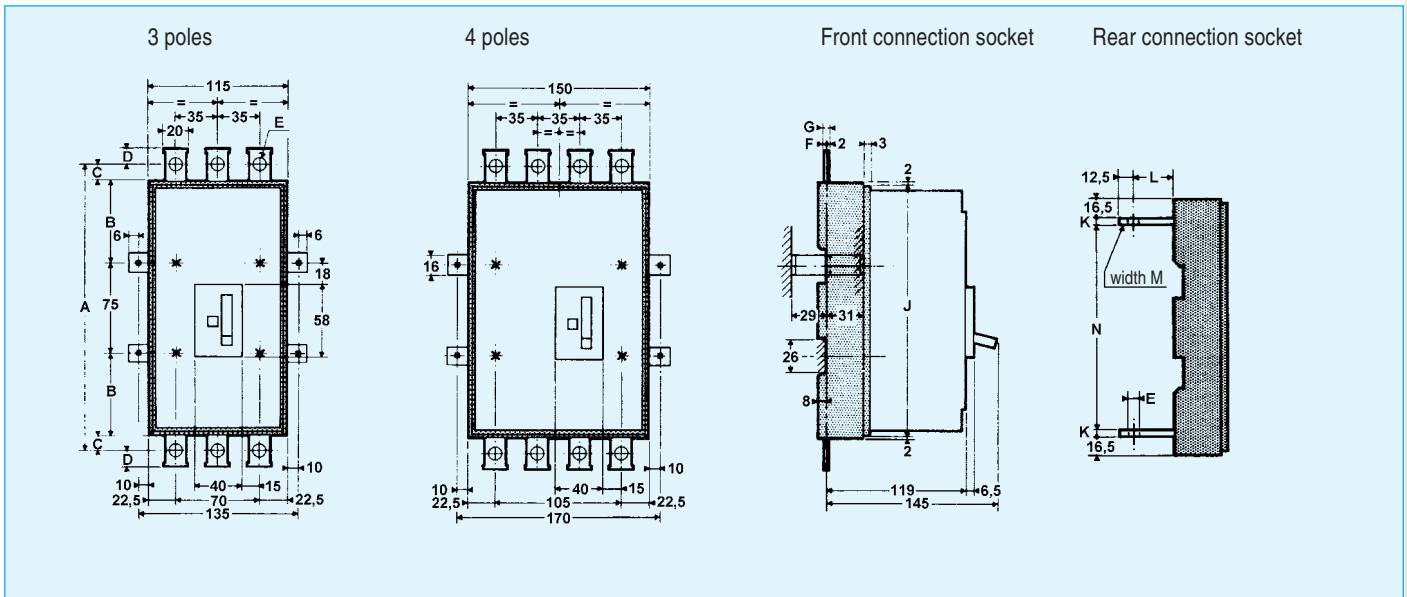

Withdrawable circuit breakers D160 L - D250 L

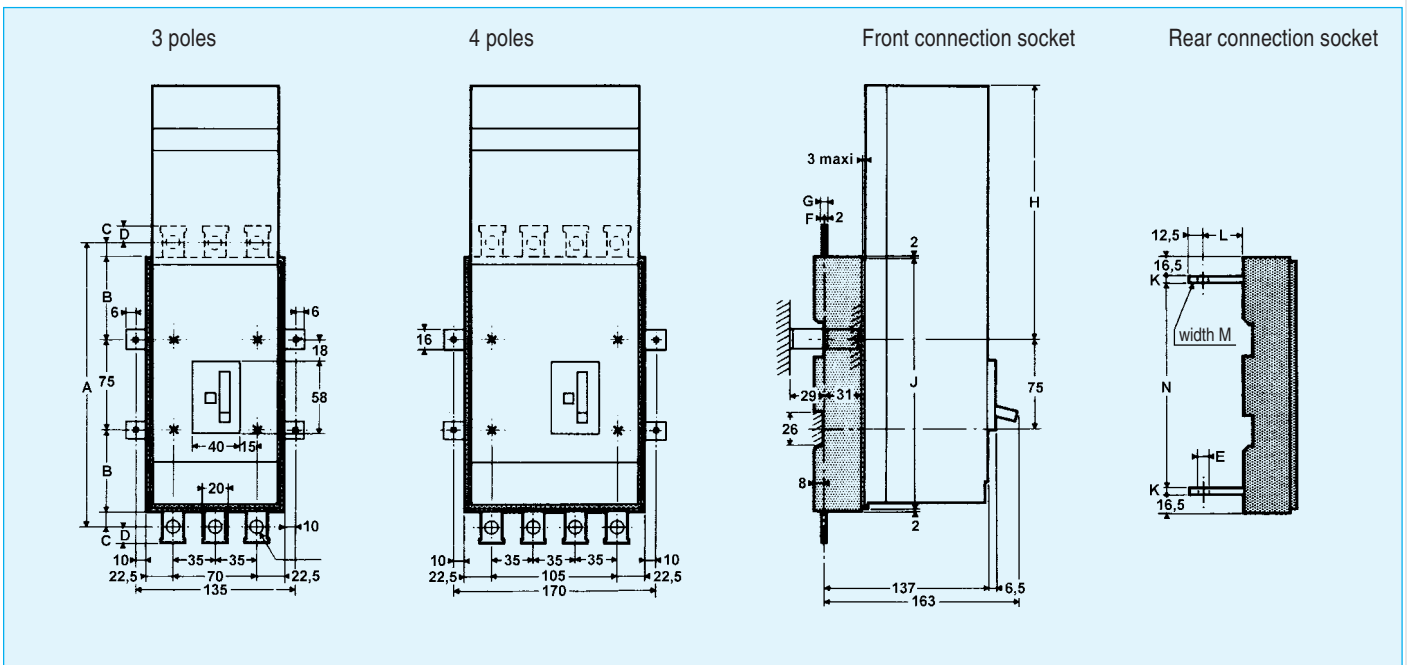

	160	250
A	193	239
B	48,5	68,5
C	10,5	13,5
D	11	13
Ø E	8,5	10,5
F	2	3
G	4	5
H	158	213
J	168	208
K	4	5
L	37,5	35
M	17	18
N	131	169

Fixation points Ø 5,5
for mounting :

* : on section
■ : on or behind panel

Withdrawable circuit breakers D160 M - DH160 M - D250 M - DH250 M

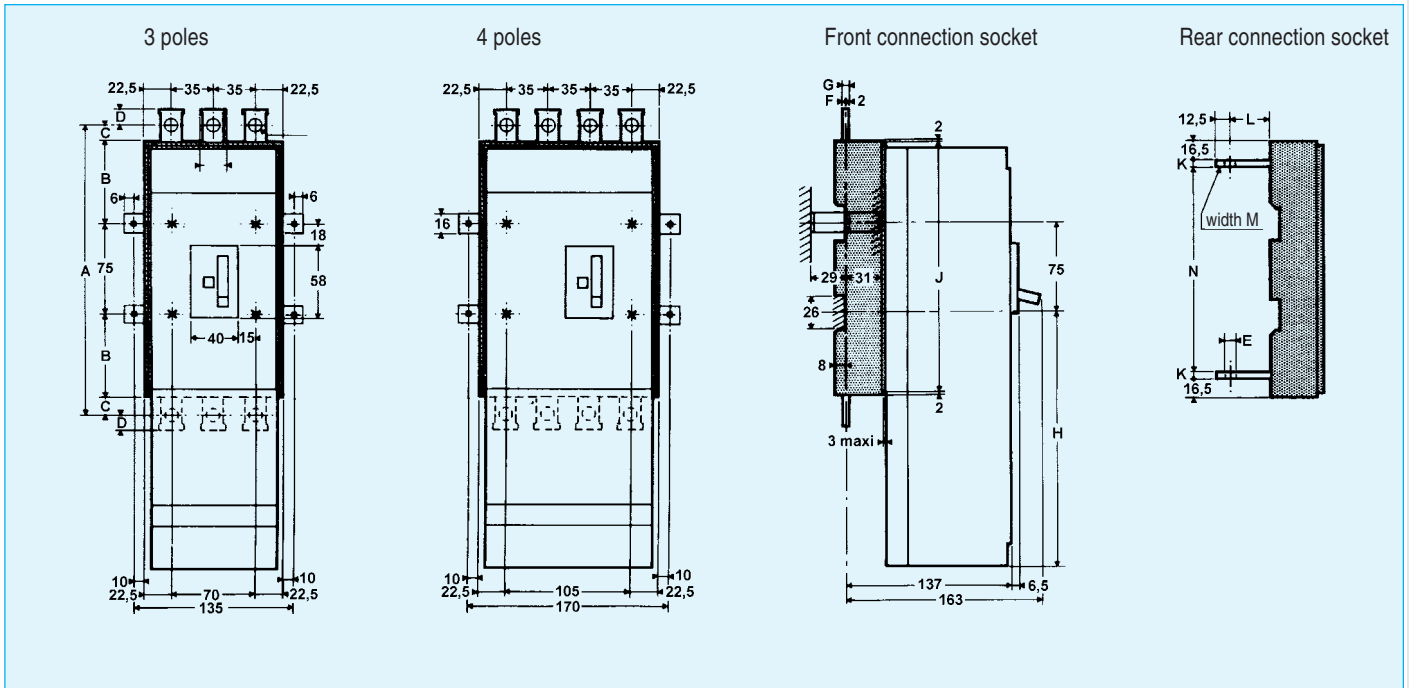

Mounting feet for withdrawable circuit breakers 160/250

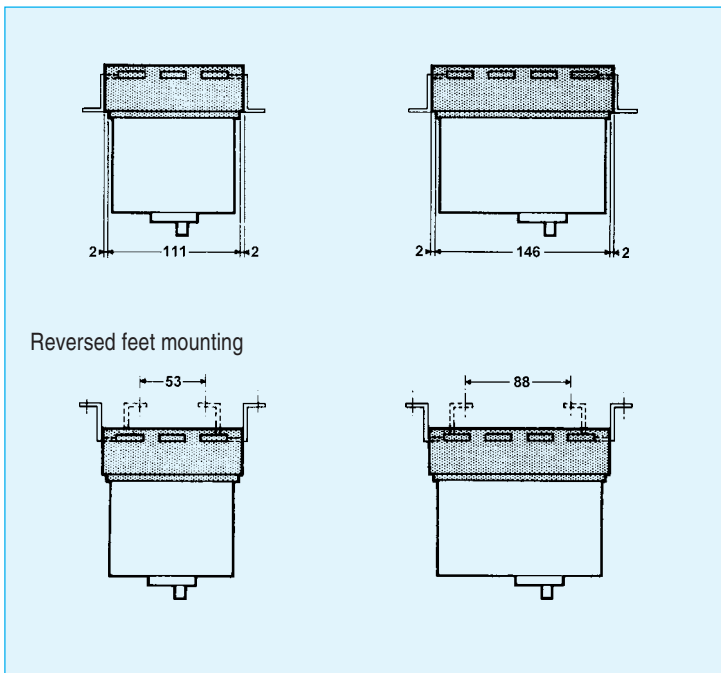

	160	250
A	193	239
B	48,5	68,5
C	10,5	13,5
D	11	13
Ø E	8,5	10,5
F	2	3
G	4	5
H	158	213
J	168	208
K	4	5
L	37,5	35
M	17	18
N	131	169

Fixation points Ø 5,5
for mounting :

* : on section

■ : on or behind panel



Withdrawable circuit breakers D400 - DH400 - D400 L - D630 - DH630 - D630 L

3/4 poles

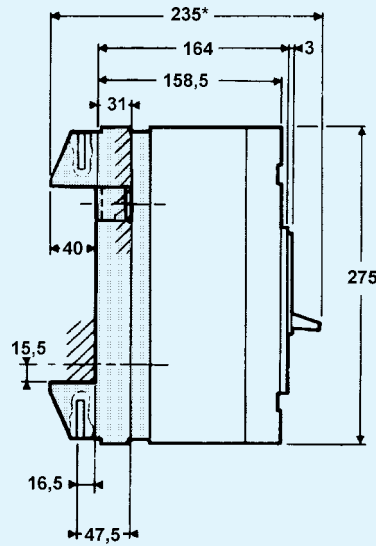
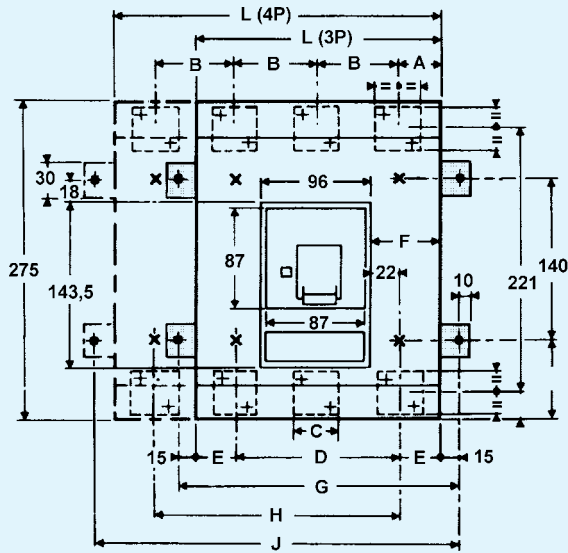

	400	630
A	25	35
B	45	70
C	27	40
D	80	140
E	30	35
F	22	57
G	170	240
H	125	210
J	215	310
Ø K	7	7
L 3p	140	210
L 4p	185	280

Fixation points Ø K for mounting :

* : on section

■ : on or behind panel

* : + 43 with extension

Withdrawable circuit breakers "Type V" D160 VE - DH160 VE - D250 VE - DH250 VE

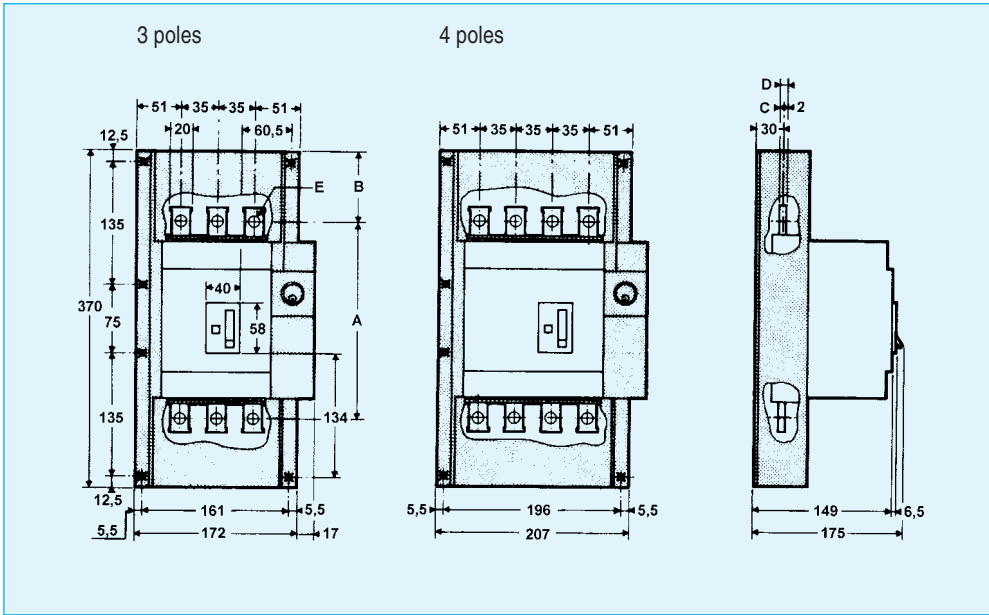

Withdrawable circuit breakers "Type V" D160 V - DH160 V - D250 V - DH250 V

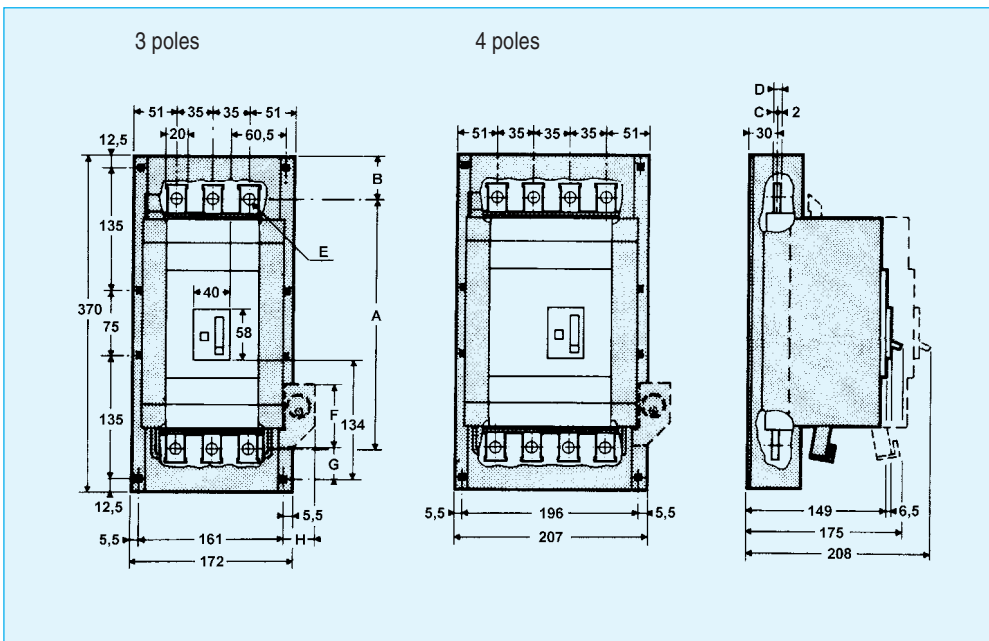

	160	250	
A	193	239	
B	88,5	65,5	
C	2	3	
D	4	5	
Ø E	8,5	10,5	
F	77	77	Ronis 1104, Profalux type
G	30	30	KS 5B 20 D4Y
H	34	34	
F	76	76	Ronis EL 11 AP
G	39	39	Profalux V 1118
H	70	70	

* : Fixation points
screw Ø M 5



Withdrawable circuit breakers "Type V" D400 VE - DH400 VE - D400 LVE - D630 VE - DH630 VE - D630 LVE

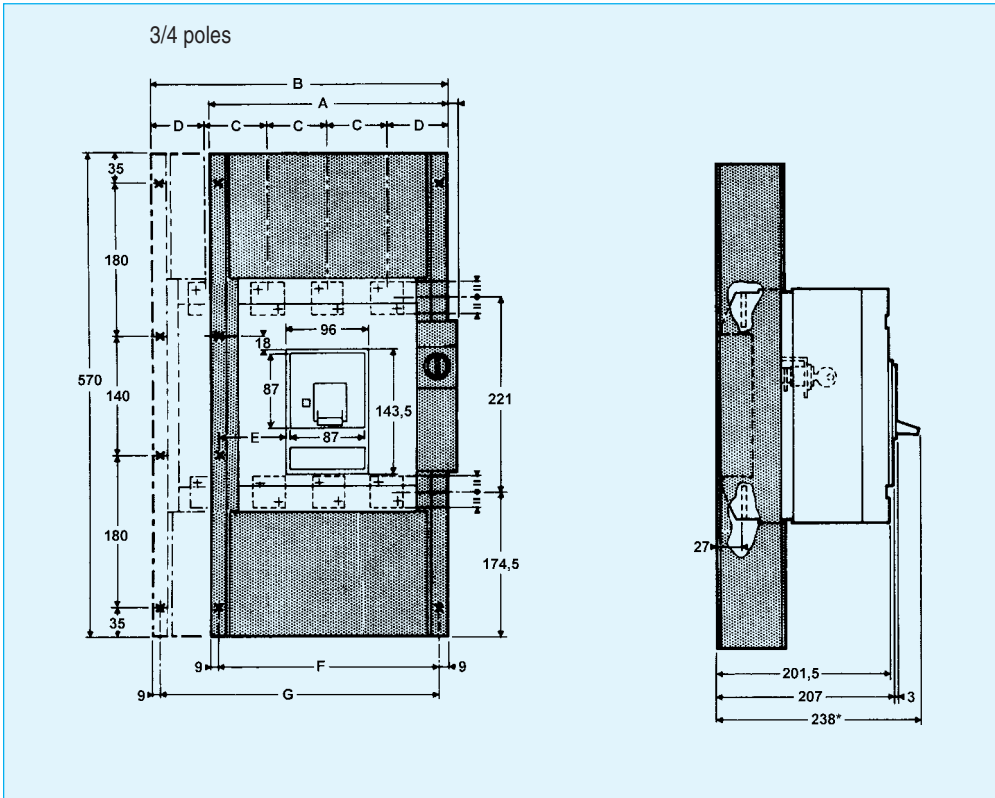

	400	630
A	208	278
B	253	348
C	45	70
D	59	69
E	47	82
F	190	260
G	235	330
M	15	25
N	25	40

* : Fixation points holes \varnothing 6,5

* : + 43 with extension

Withdrawable circuit breakers "Type V" D400 VR - DH400 VR - D400 LVR

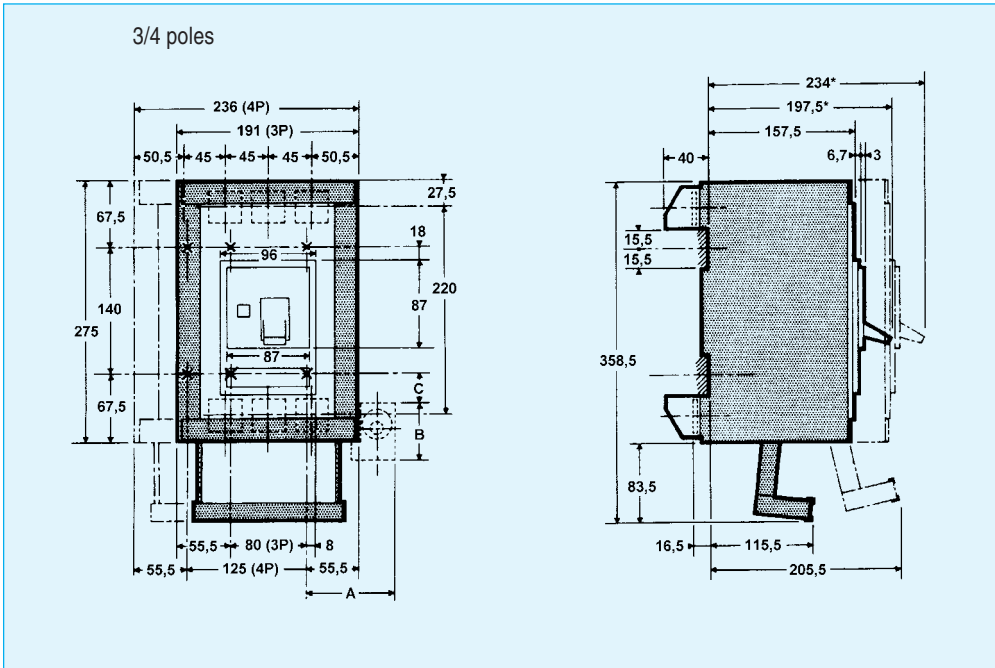

	A	B	C
Ronis 1104	90,5	58	31,5
Profalux KS 5B 20			
Ronis EL 11 AP	127,5	49	27,5
Profalux V 1118			

* : Fixation points holes \varnothing 7

* : + 43 with extension

Withdrawable circuit breakers "Type V" D630 VR - DH630 VR - D630 LVR

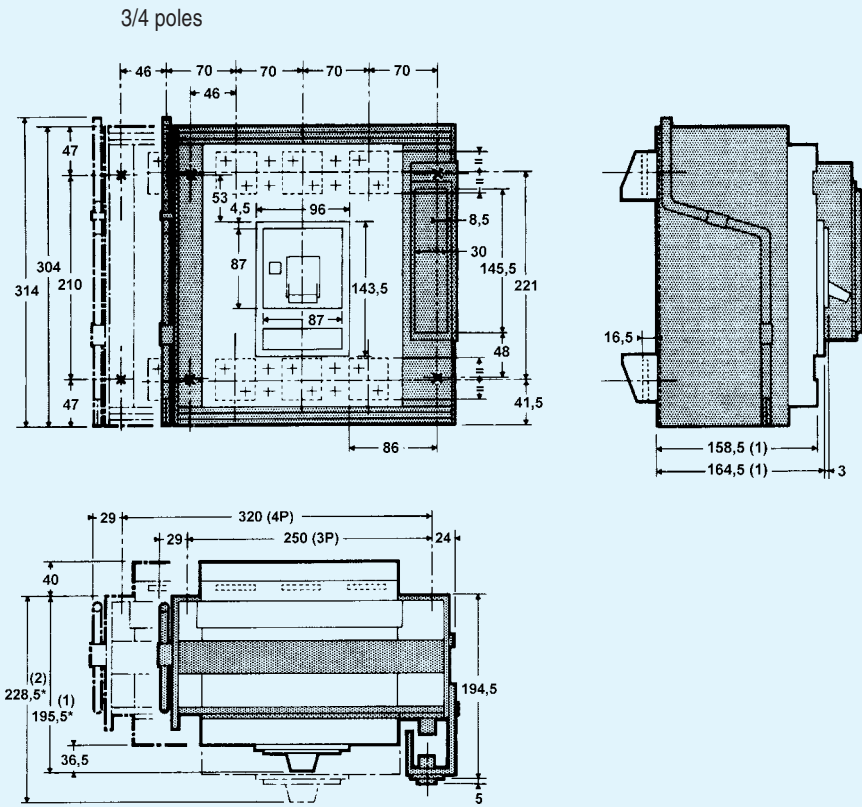

* : Fixation points
holes \varnothing 7
(1) : plugged-in
(2) : withdrawn

* : + 43 with extension

Drilling diagram

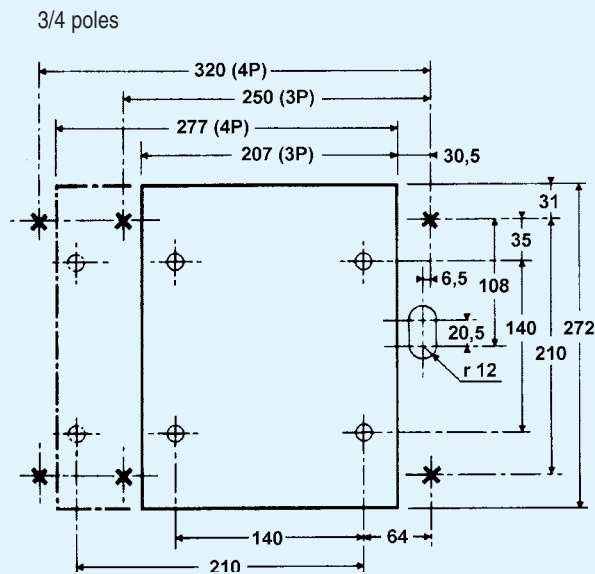

* : Fixation points
on panel holes \varnothing 7

⊕ : Fixation points
on bar holes \varnothing 7



Withdrawable circuit breakers "Type V" D400 VR - DH400 VR - D400 LVR

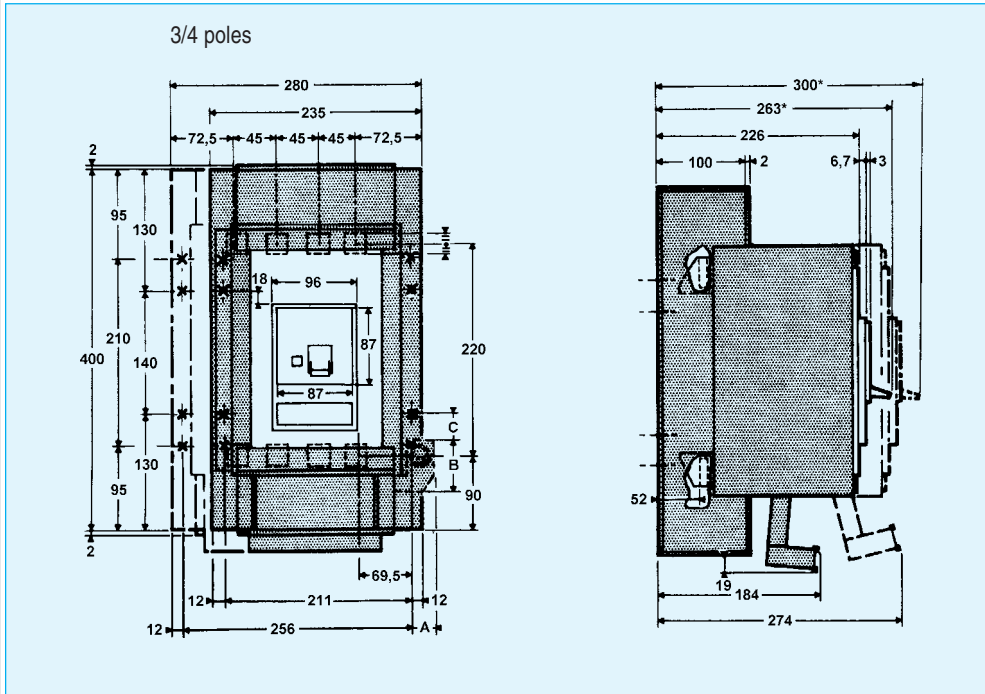

	A	B	C
Ronis 1104	25	58	31,5
Profalux KS 5B 20			
Ronis EL 11 AP	62	49	27,5
Profalux V 1118			

* : Fixation points holes Ø 10

* : + 43 with extension

Withdrawable circuit breakers "Type V" D630 V - DH630 V - D630 LV

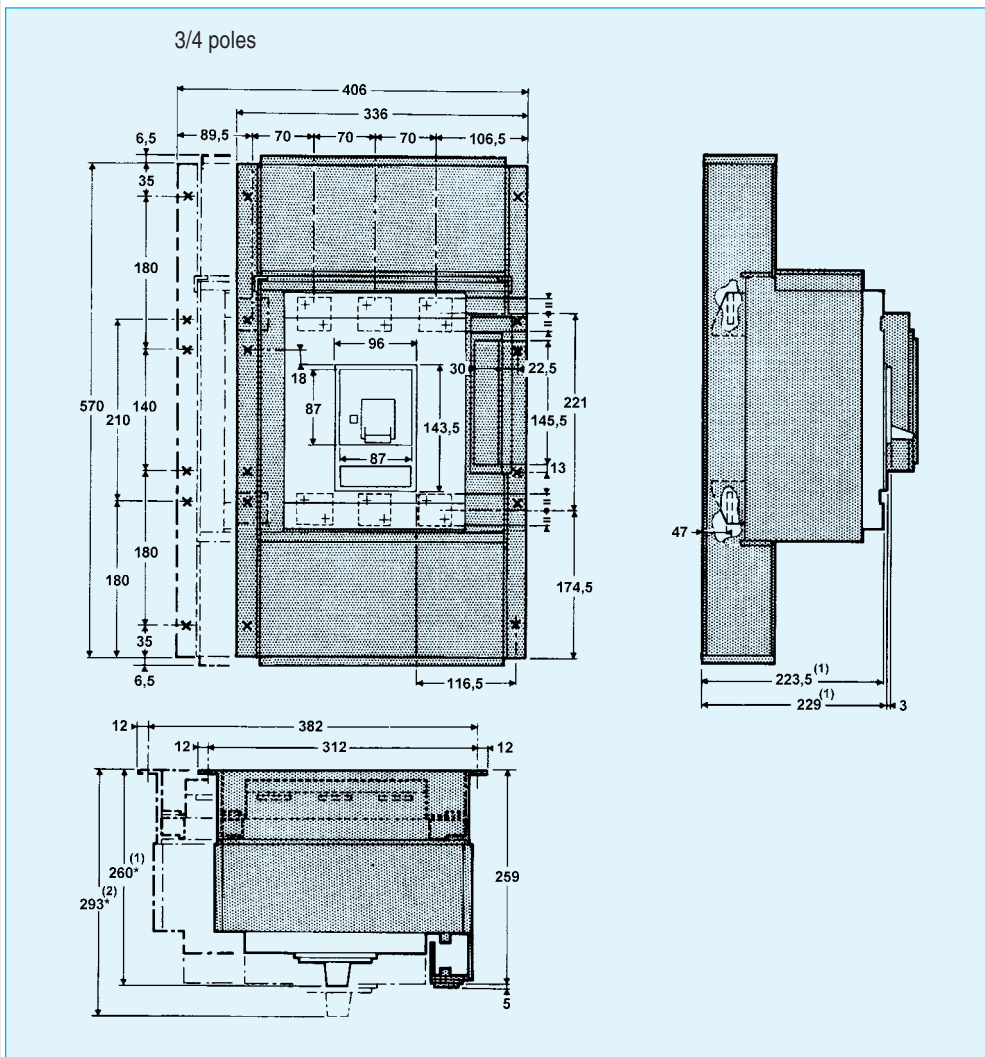



Withdrawable circuit breakers "Type V" D800 V - DH800 V

A
114

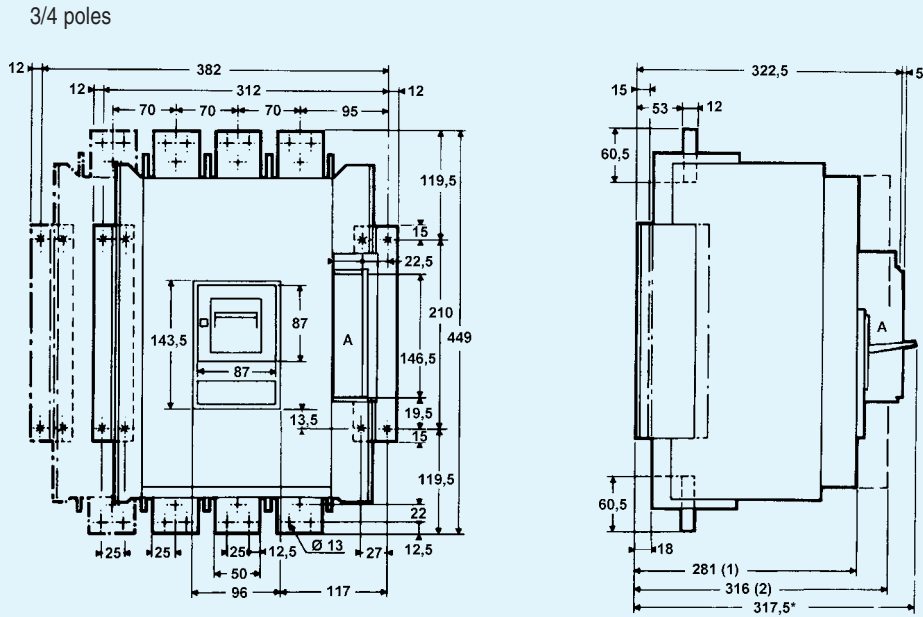

- * : Fixation points
holes \varnothing 10
- (1) : plugged-in
- (2) : withdrawn
- A : device for locking
in "removed" position
- * : + 43 with extension



Withdrawable circuit breakers "Type V" D1250 V

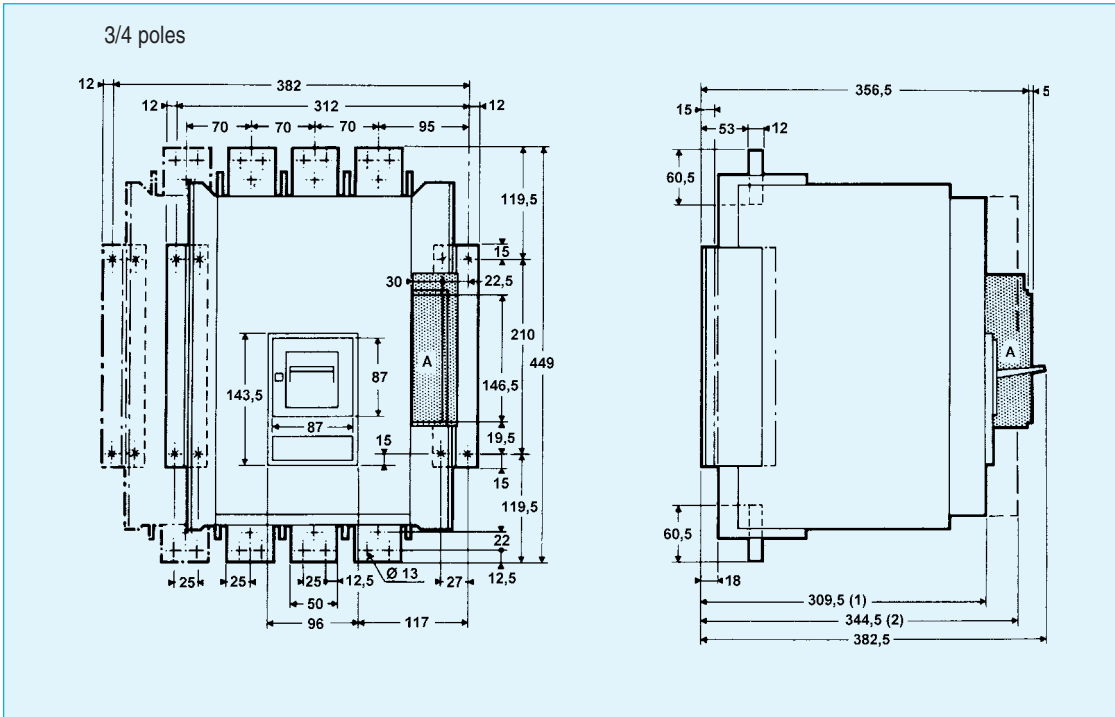

Wall mounting enclosure for withdrawable circuit breakers "Type V" D1250 V

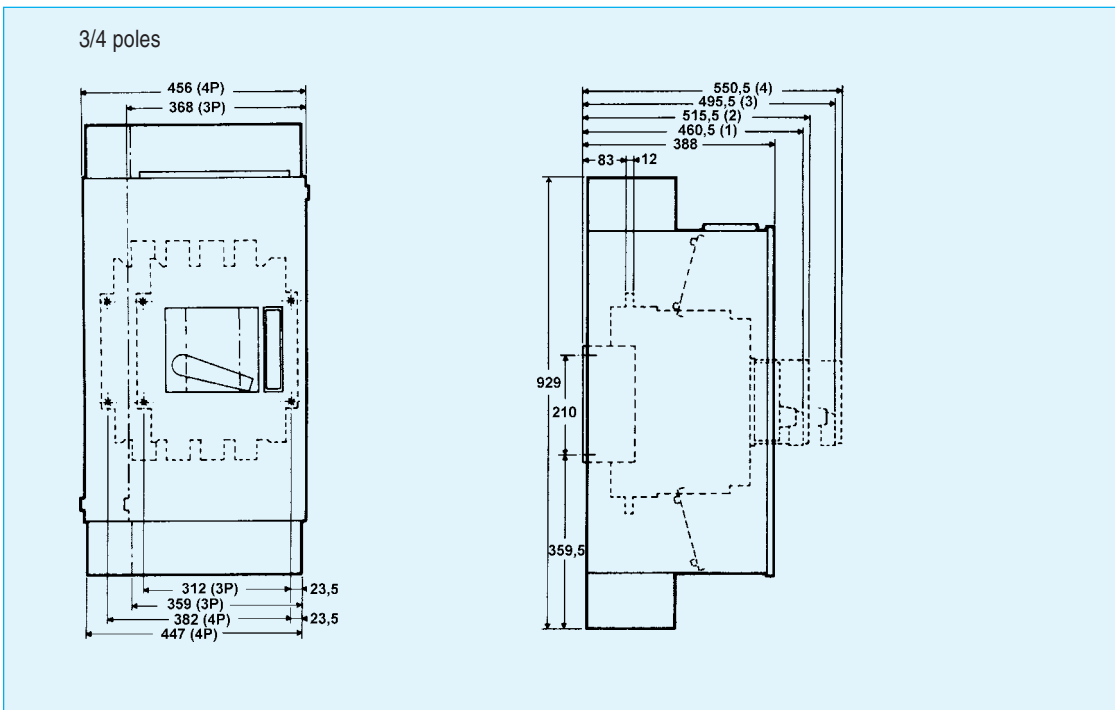

- (1) Plugged-in with electrical control
- (2) Plugged-in with manual rotary control
- (3) Withdrawn with electrical control
- (4) Withdrawn with manual rotary control



A
116

Electrical control for D125

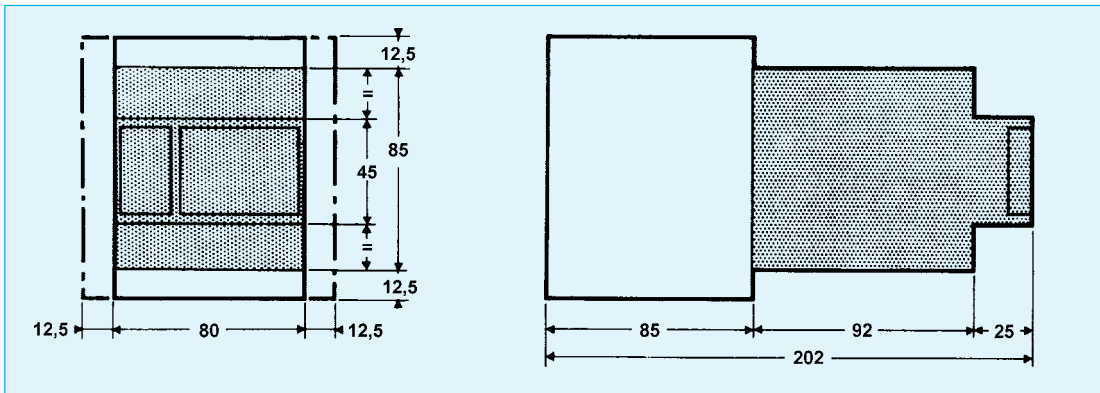

Electrical control for D160 - D250

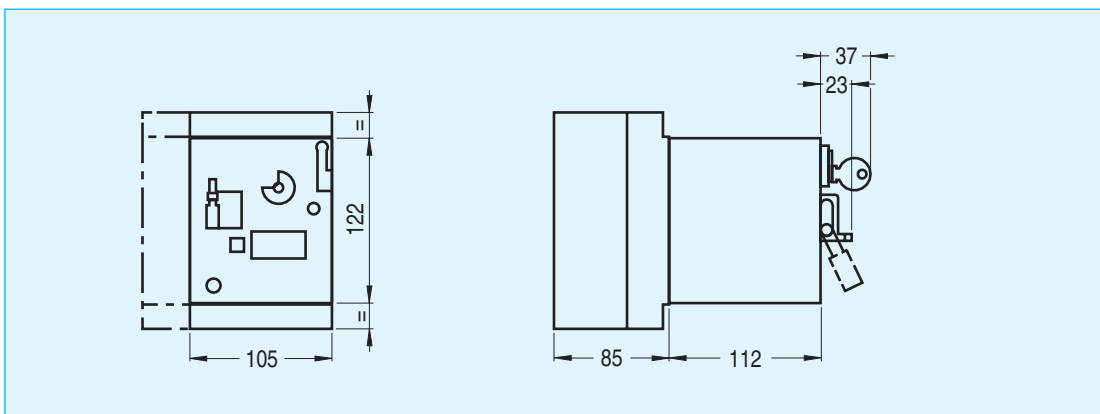

Electrical control for D400 - D630 - D800

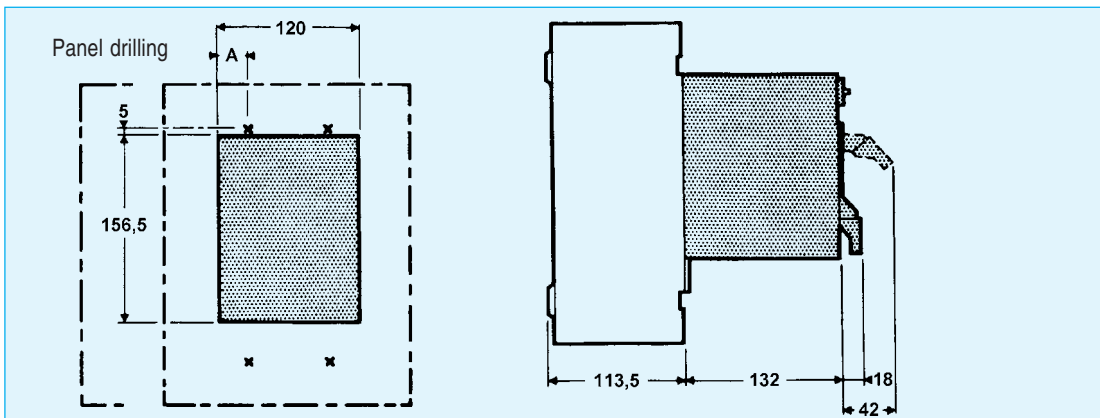

	400	630	800
A	37.5	25	25

Electrical control for D1250

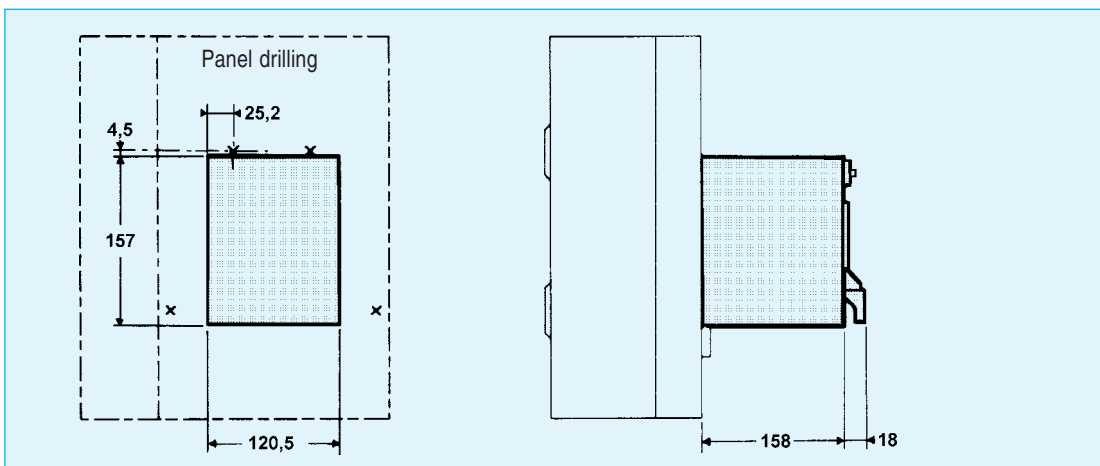



Rotary controls for D125

Direct on circuit breaker

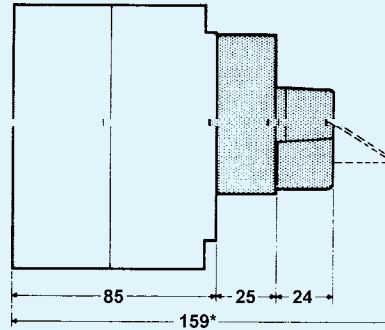
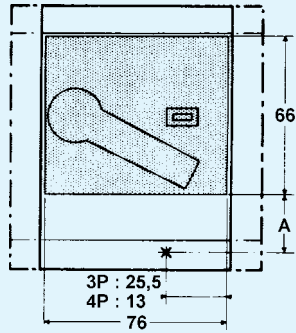

	D125	D125 M
A	24	64

* : locking lever
(3 padlocks)

With removable handle for circuit breakers behind door or panel

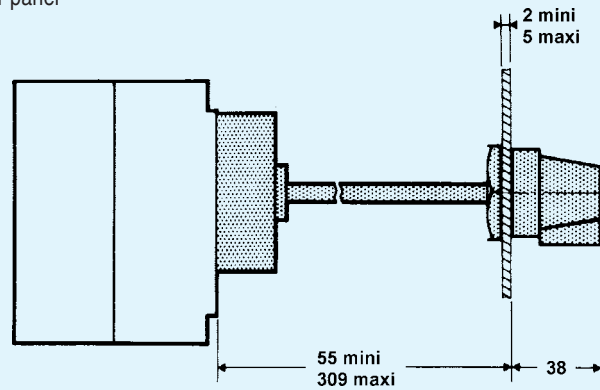
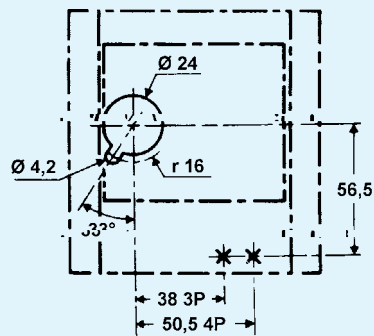

Disengageable for circuit breakers behind door or panel

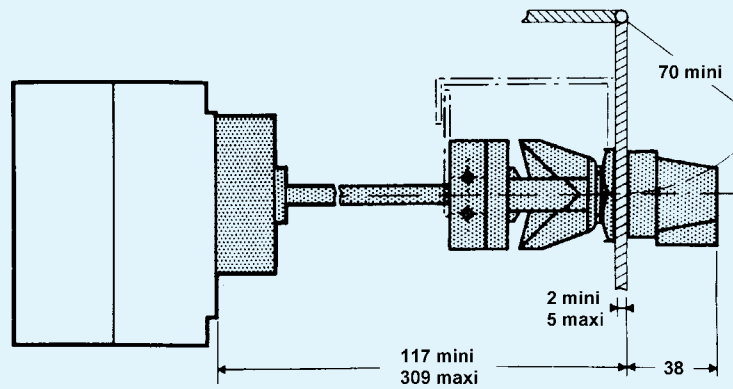
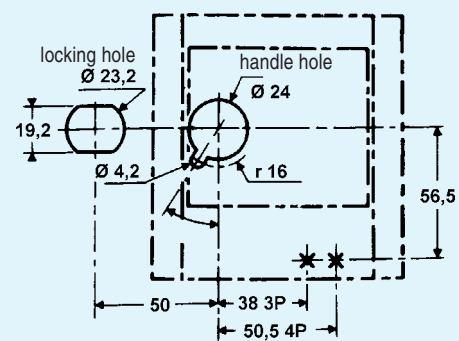



Rotary controls for D160 - D250

Direct on circuit breaker

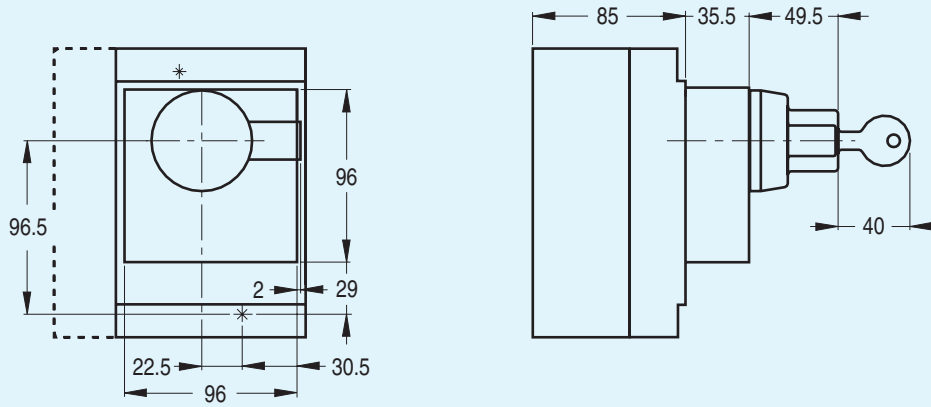

* : Fixation points screw M5

With removable handle for circuit breakers behind door or panel

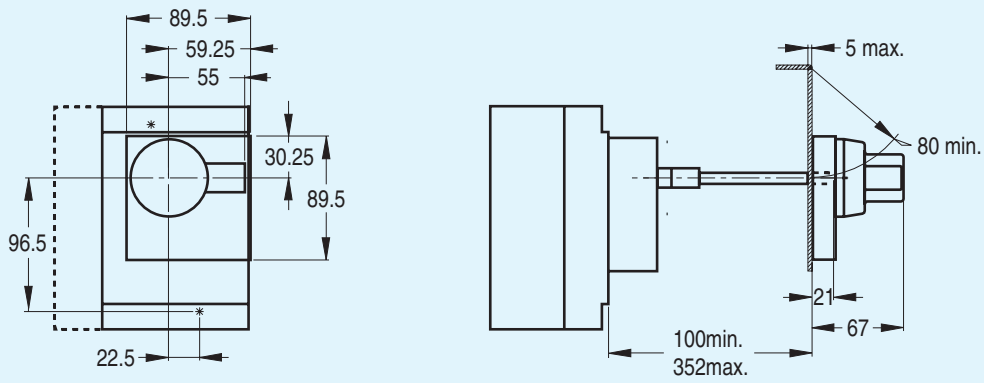

Drilling diagram (installation at 90°)

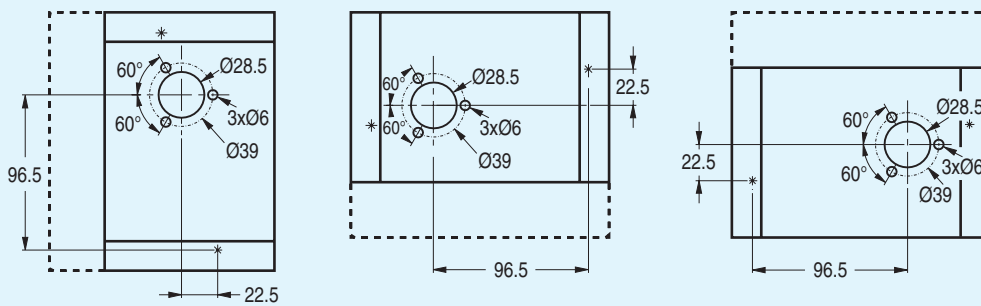



Rotary controls for D400 - D630 - D800

Direct on circuit breaker

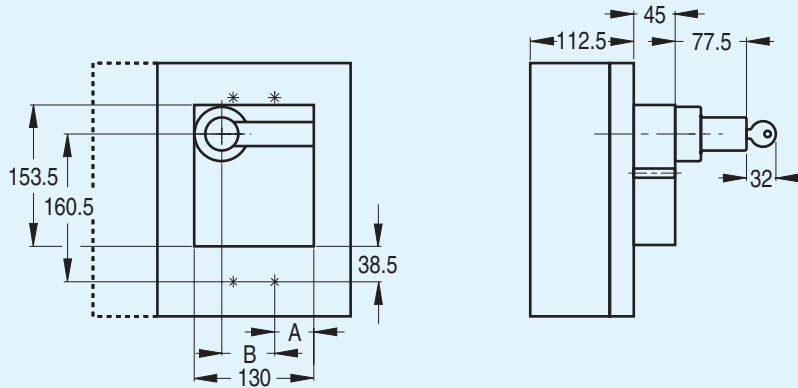

	400	630 - 800
A	42.5	30
B	57.5	70

With removable handle for circuit breakers behind door or panel

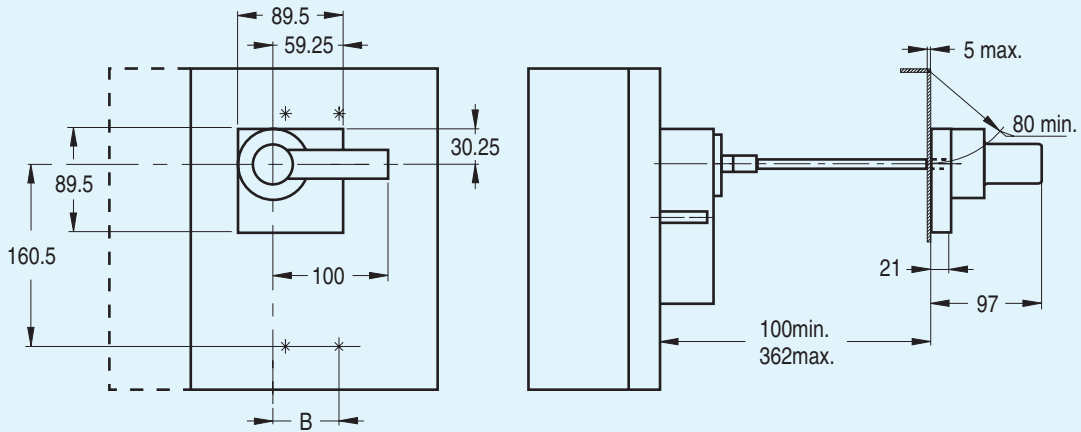

Drilling diagram (installation at 90°)

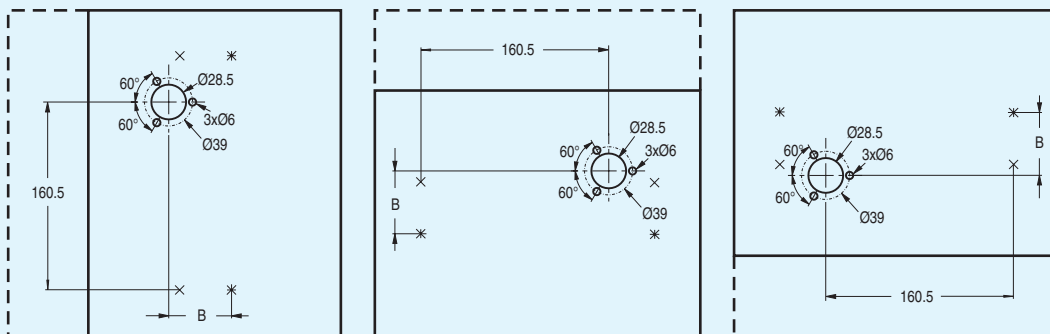



Rotary controls for D1250

Direct on circuit breaker

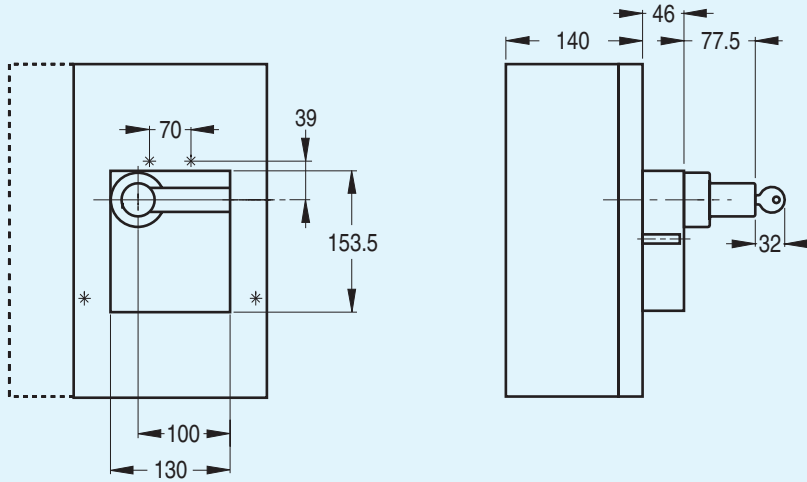

With removable handle for circuit breakers behind door or panel

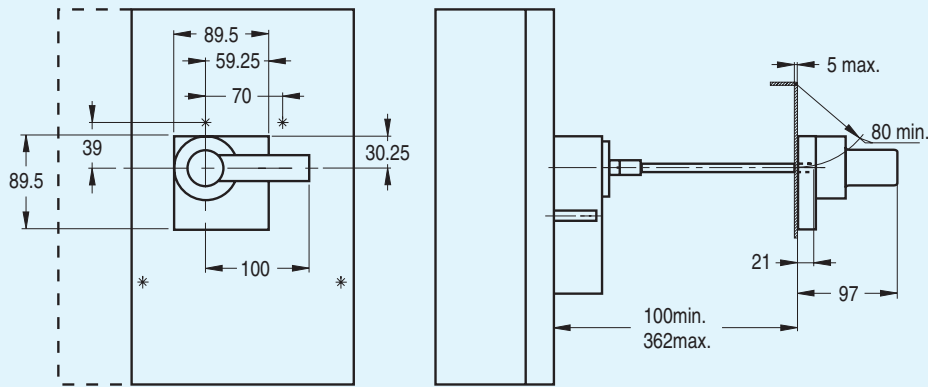

Drilling diagram (installation at 90°)

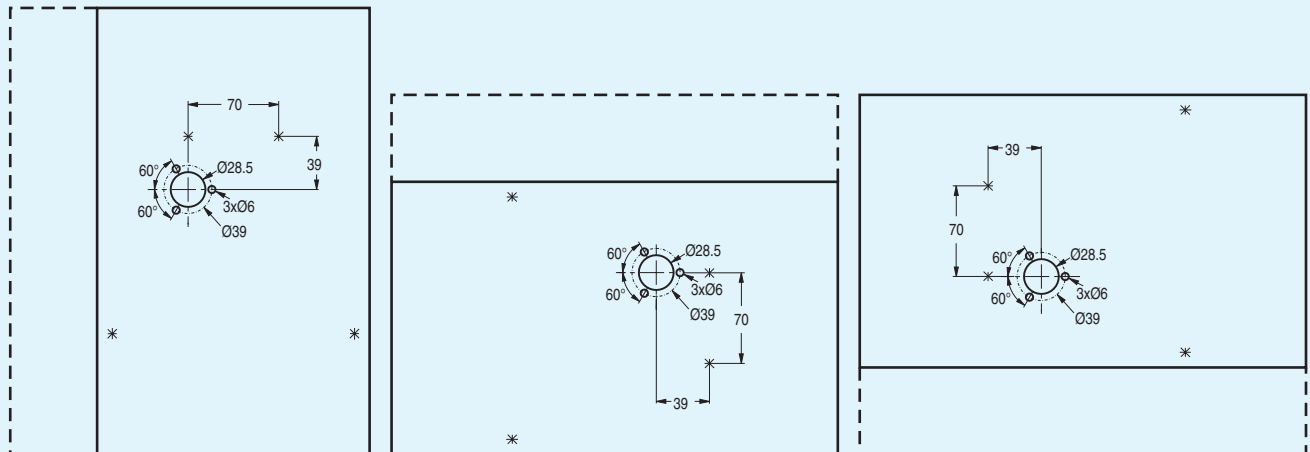



Sealable terminal covers

Circuit breakers D125

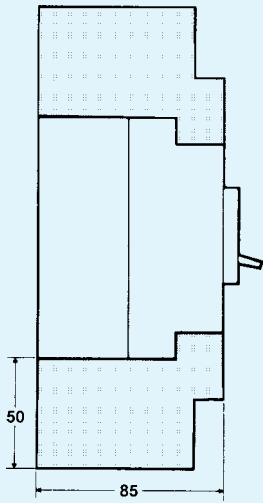

A
121

Circuit breakers D160 - D250

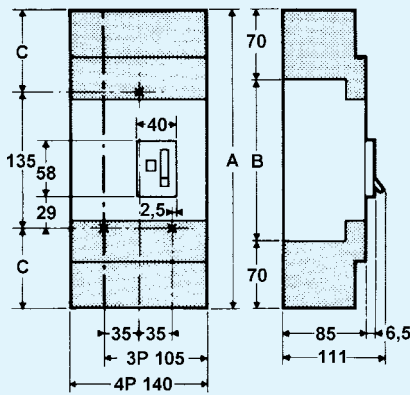

	D160	D250
A	300	340
B	160	200
C	82.5	102.5

* : fixation points
screw M5

Circuit breakers D400

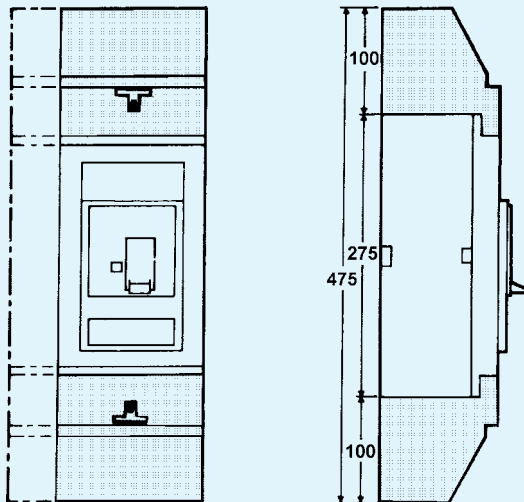



Locking systems

Control handle in the "OFF" position, circuit breakers D125

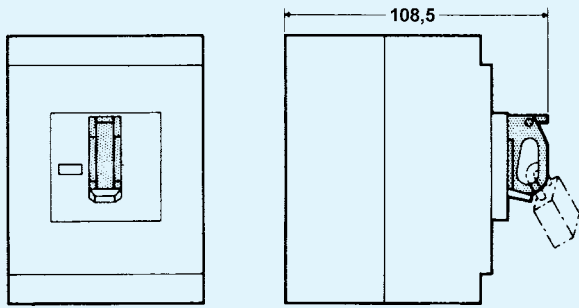

Control handle in the "OFF" position, circuit breakers D400/630/800
1) with padlocks (removable unit)

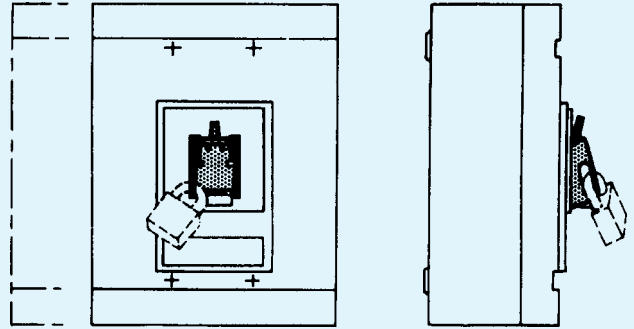

Control handle in the "OFF" position, circuit breakers D160/250
1) with padlocks (removable unit)

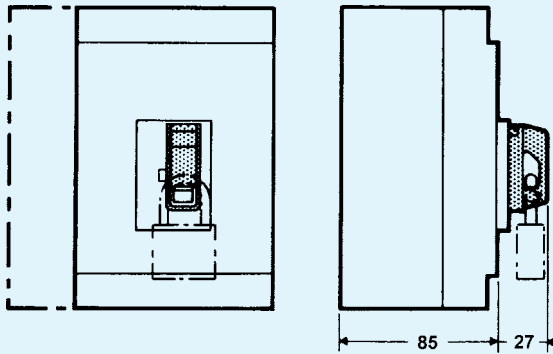

2) with padlocks or lock

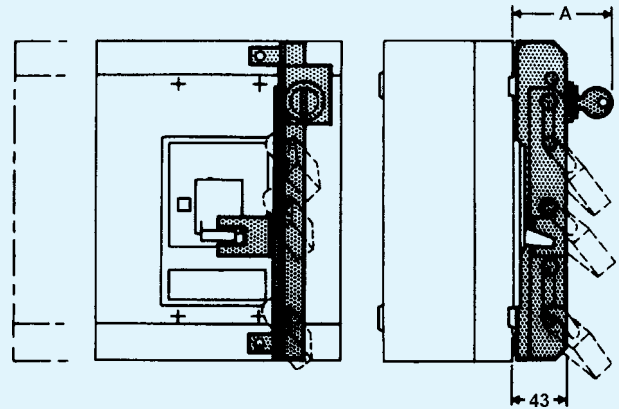

2) with padlocks or lock

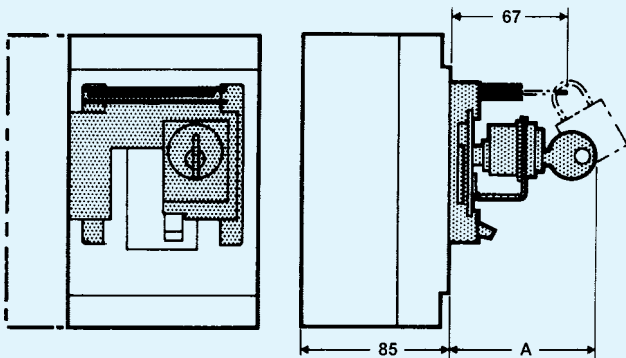

A : 78 (lock: Ronis)
90 (lock: Profalux)

	400	630/800
A (Ronis)	85	80.5
A (Profalux)	103	98.5

Control handle in the "OFF" position, circuit breakers D1250

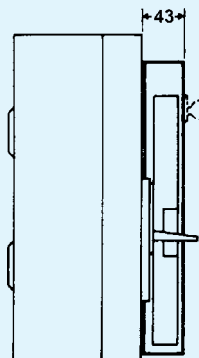



Fixing plate

For D125 circuit breakers, mounting on DIN rail, 35 mm
1) front or rear connection

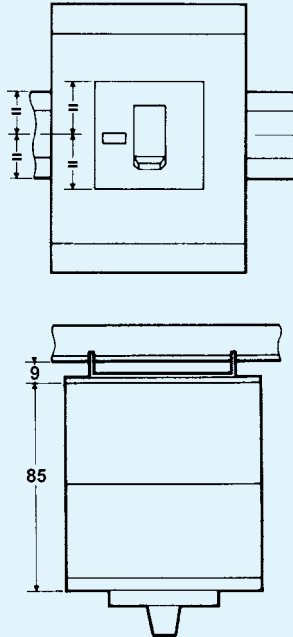

For circuit breakers D160 - D250
1) mounting on DIN rail, 35 mm

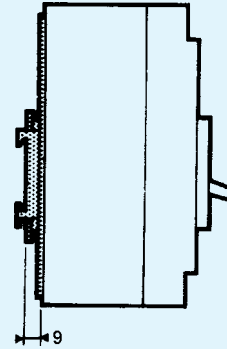

2) mounting on section or bars

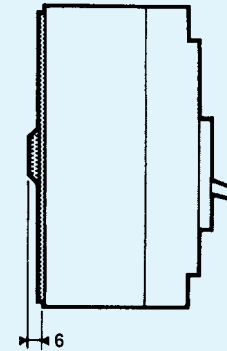

2) front or rear connection: 2 poles
rear connection only: 3 and 4 poles

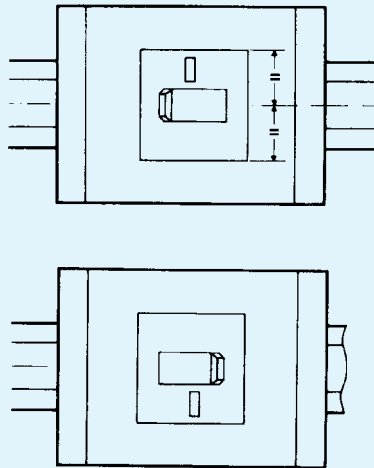

For circuit breakers D400 - D630 - D800 mounting on section or bars,
circuit breaker with rear connections

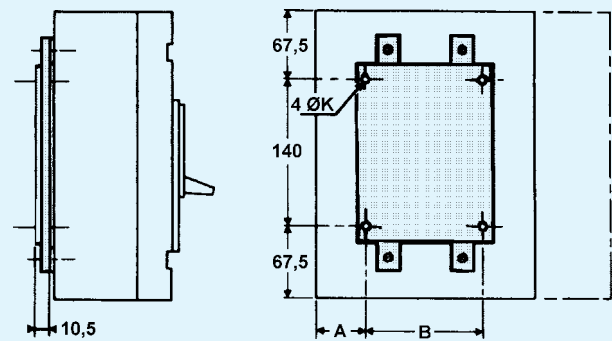

	400	630	800
A	(1)	50	50
B	125	110	110
K	6.5	8	9

(1) : 7.5 (3 poles)
30 (4 poles)



Fixed changeover switches D160 IDS - D250 IDS

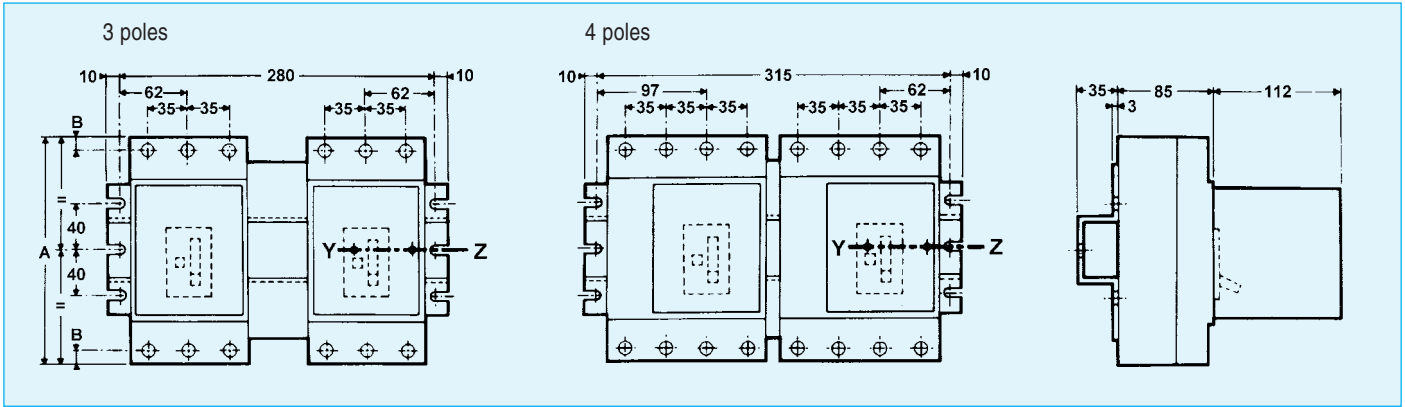

	A	B
160	160	12,5
250	200	14

Fixed changeover switches D160 L IDS - D250 L IDS

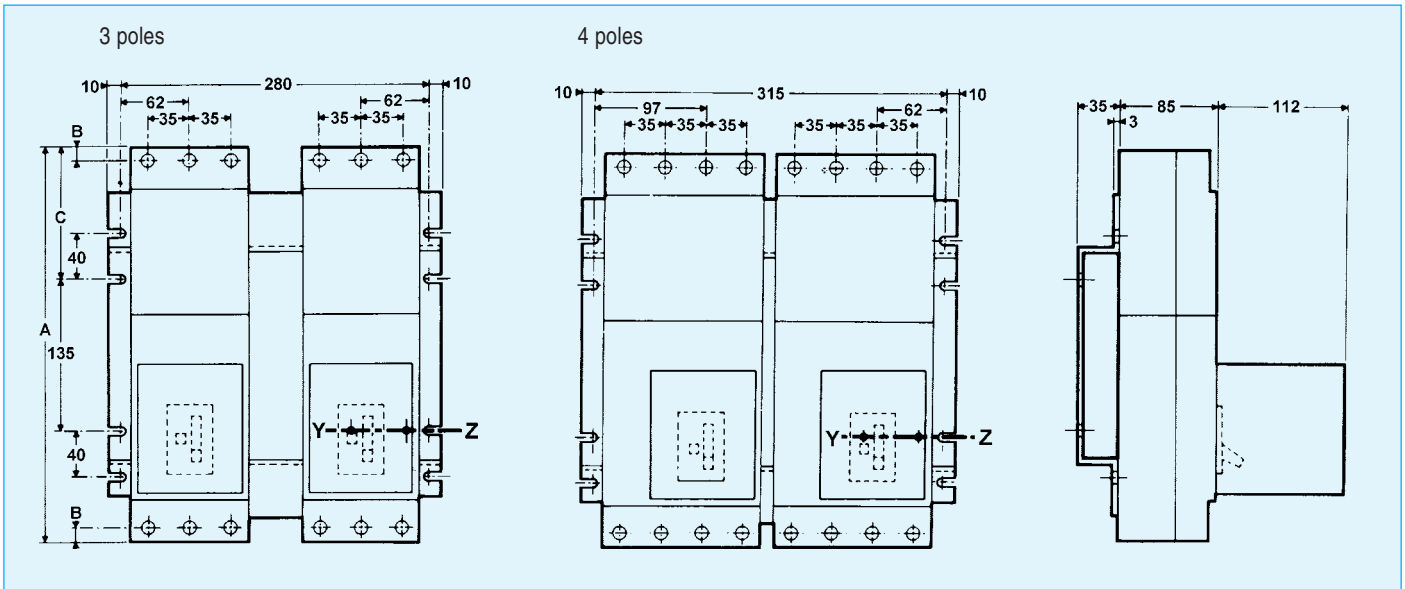

	A	B	C	E
160	275	12,5	80	115
250	350	14	115	135

Automatic controller plate

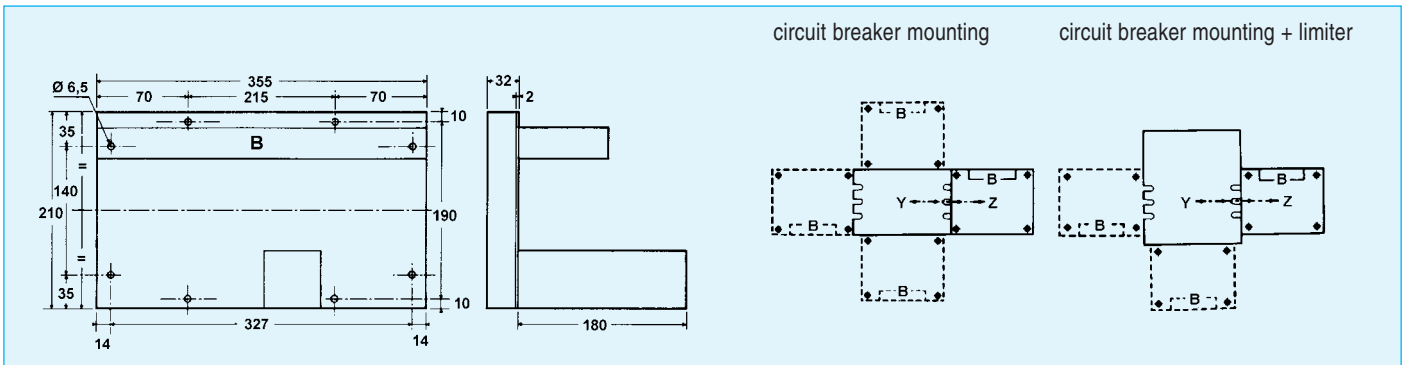

- ⊕ : fixation points for screw Ø 6
- Y - Z : mounting axis for automatic controller plate
- B : customer terminal board



Withdrawable changeover switches D160 IDS - D250 IDS

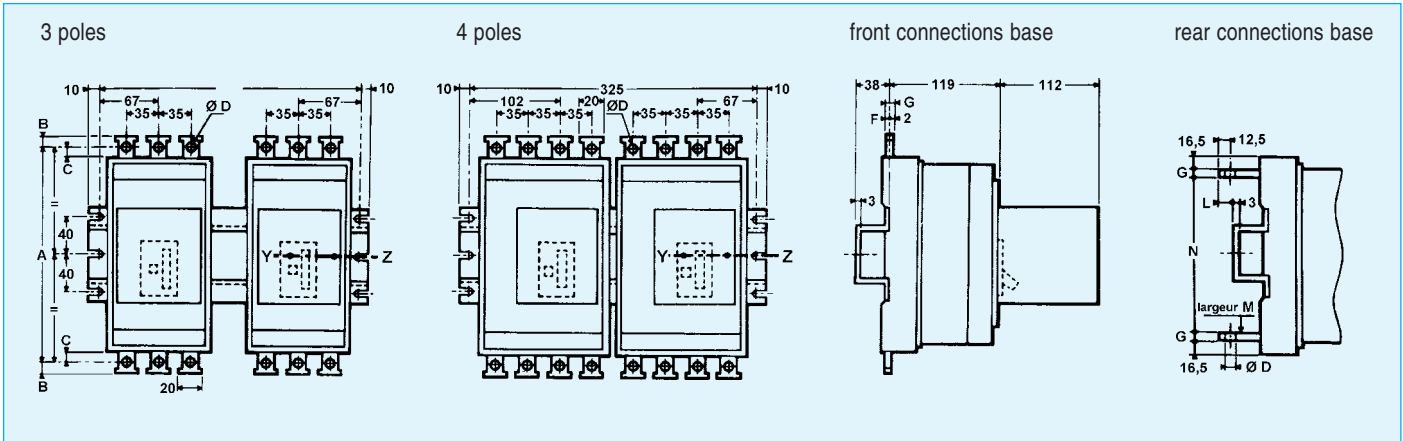

Withdrawable changeover switches D160 L IDS - D250 L IDS

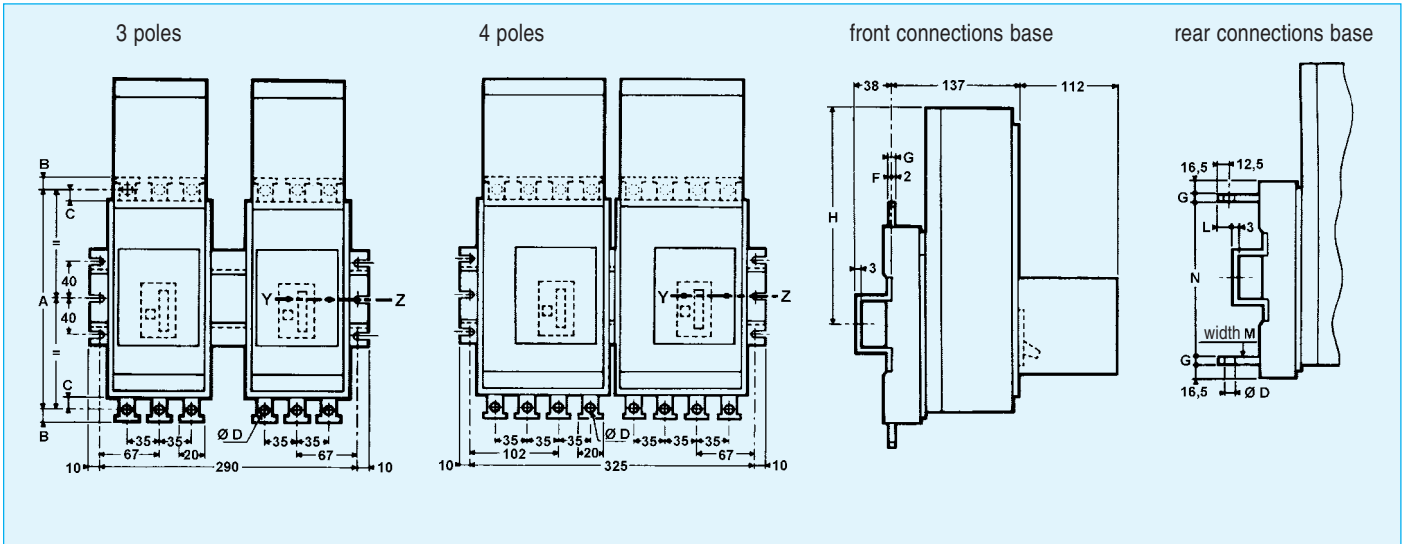

	A	B	C	Ø D	F	G	H	L	M	N
160	193	11	10.5	8.5	2	4	195.5	20	17	131
250	239	13	13.5	10.5	3	5	250.5	17.5	18	169

Automatic controller plate

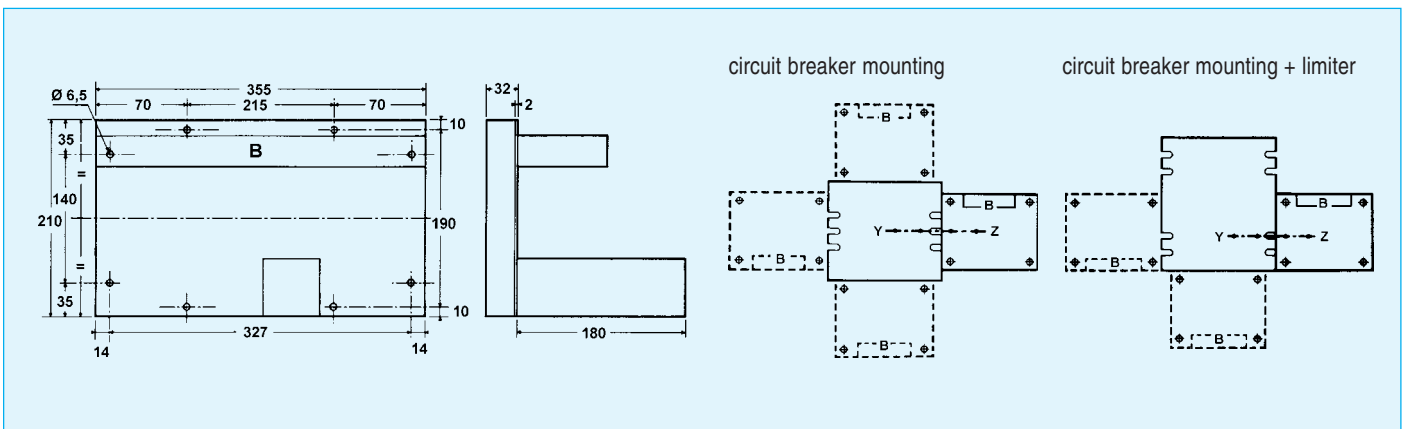

- ⊕ : fixation points for screw Ø 6
- Y - Z : mounting axis for automatic controller plate
- B : customer terminal board



Fixed changeover switches D400 IDS - DH400 IDS - D400 L IDS - D630 IDS - DH630 IDS - D630 L IDS - D800 IDS - DH800 IDS

Automatic controller plate

3/4 poles

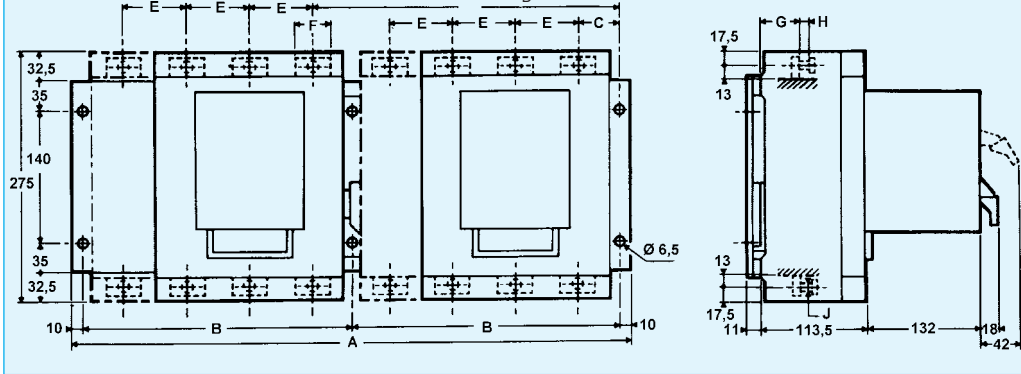

D400 IDS - D630 IDS
D800 IDS - D1250 IDS

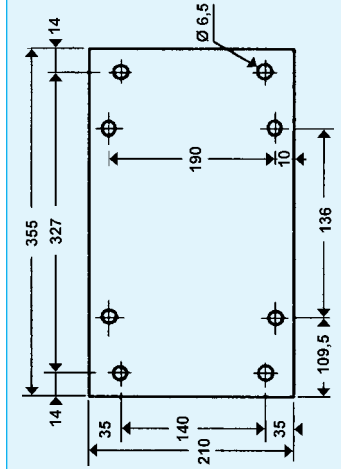

	A	B	C	D	E	F	G	H	ØJ
400	430	205	36	239	45	32	35.5	11	10
630	620	300	46	344	70	40	41	12	12
800	620	300	46	344	70	40	41	12	12

Fixed changeover switches D/J1250 IDS

3/4 poles

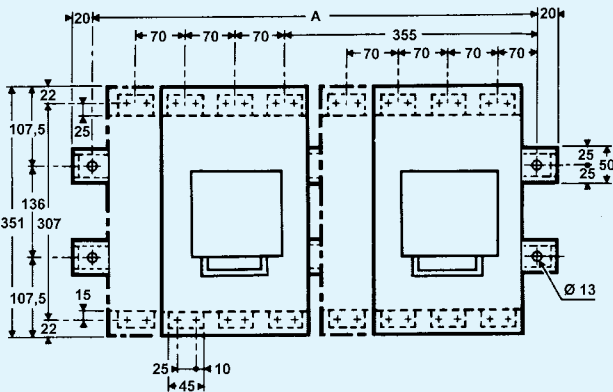

A 3p : 560
A 4p : 630
PF : fixation diagram

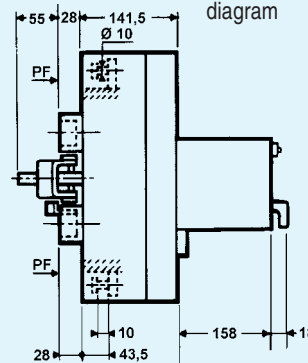

Withdrawable changeover switches D400 IDS - DH400 IDS - D400 L IDS - D630 IDS - DH630 IDS - D630 L IDS

3/4 poles

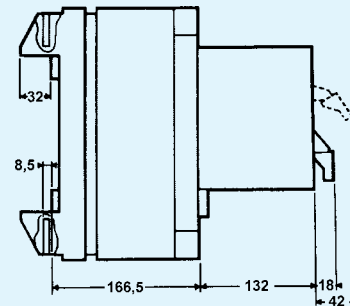
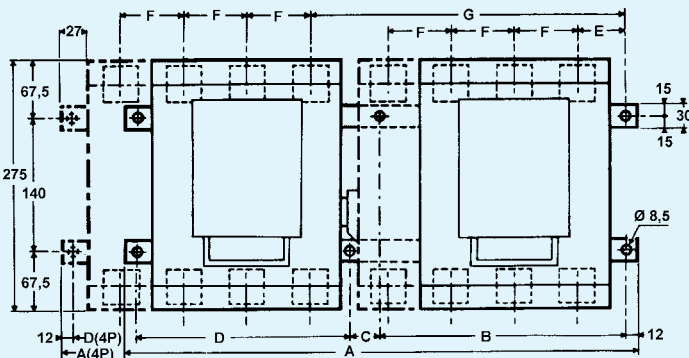

	A 3p	A 4p	B	C	D 3p	D 4p	E	F	G
400	397	442	186.5	22.5	164	209	40	45	243
630	562	632	269	35	234	304	50	70	348



Fixed circuit breakers D125

Front with tunnel terminals for cables without lugs
 Capacity : min. 2.5 mm² max. 50 mm²
 Torque :
 section ≤ 10mm² 3 N.m
 section ≥ 16 mm² 5 N.m

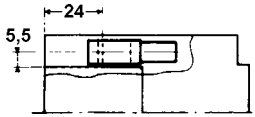

Rear connections for bars or cables with lugs
 Bar width max. 20 mm
 Torque :
 rear connection 3.5 N.m (M6)
 bar or cable with lug 3.5 N.m (M6)

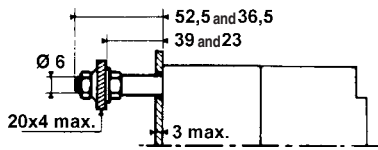

Withdrawable circuit breakers D125

Front with tunnel terminals for cables without lugs
 Capacity : min. 2.5 mm² max. 50 mm²
 Torque :
 section ≤ 10mm² 3 N.m
 section ≥ 16 mm² 5 N.m

Terminals accessible from the front for device mounted on panel or on section

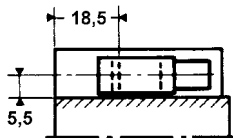

Rear with tunnel terminals for cables without lugs
 Capacity : min. 2.5 mm² max. 50 mm²
 Torque :
 section ≤ 10mm² 3 N.m
 section ≥ 16 mm² 5 N.m

Terminals accessible from the rear for device mounted behind panel or on section

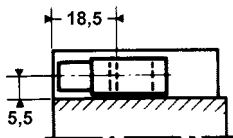

Rear connections for bars or cables with lugs
 Bar width max. 20 mm
 Torque :
 rear connection 3.5 N.m (M6)
 bar or cable with lug 3.5 N.m (M6)

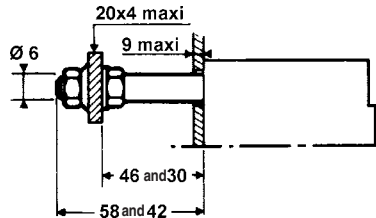

Fixed circuit breakers D160

Front for bars or cables with lugs
 Bar width max. 22 mm
 Torque :
 bar or cable with lug 8 N.m (M6)

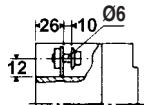

Front extender for bars or cables with lugs
 Bar width max. 22 mm
 Torque :
 extender 8 N.m (M6)
 bar or cable with lug 14 N.m (M8)

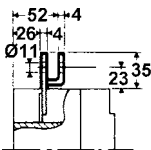

Front with tunnel terminals for cables without lugs
 Capacity : min. 16 mm² max. 95 mm²
 Torque :
 section from 16 to 95 mm² 17 N.m

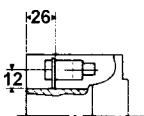

Front with sloped tunnel terminals for cables without lugs
 capacity : min. 16 mm² max. 95 mm²
 Torque :
 sloped extender 8 N.m (M6)
 section from 16 to 95 mm² 17 N.m

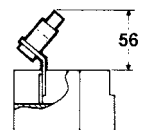

Rear connections for bars or cables with lugs
 Bar width max. 22 mm
 Torque :
 rear connection 10 N.m (M6)
 bar or cable with lug 7 N.m (M8)

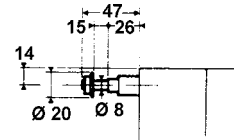

Rear connections for cables without lugs
 Capacity : min. 16 mm² max. 95 mm²
 Torque :
 rear connection 10 N.m (M6)
 section from 16 to 95 mm² 17 N.m

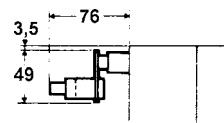

Withdrawable circuit breakers D160

Front for bars or cables with lugs
 Bar width max. 22 mm
 Torque :
 bar or cable with lug 14 N.m (M8)

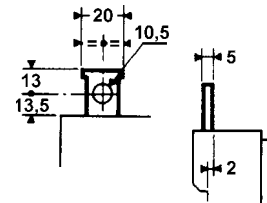

Front with tunnel terminals for cables without lugs
 Capacity : min. 16 mm² max. 95 mm²
 Torque :
 section from 16 to 95 mm² 17 N.m

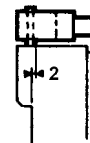

Front with sloped tunnel terminals for cables without lugs
 Capacity : min. 16 mm² max. 95 mm²
 Torque :
 sloped extender 8 N.m (M6)
 section from 16 to 95 mm² 17 N.m

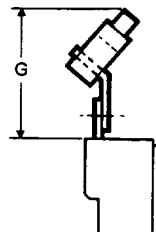

Rear connections for bars or cables with lugs
Bar width max. 22 mm
Torque: bar or cable with lug 14 N.m (M8)

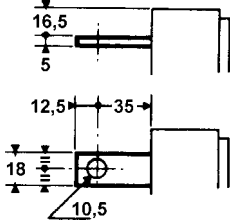

Fixed circuit breakers D250

Front for bars or cables with lugs
Bar width max. 25 mm
Torque: bar or cable with lug 14 N.m (M8)

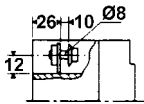

Front extender for bars or cables with lugs
Bar width max. 25 mm
Torque: extender 14 N.m (M8)
bar or cable with lug 28 N.m (M10)

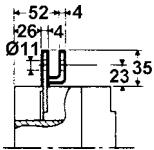

Front with tunnel terminals for cables without lugs
Capacity : min. 35 mm² max. 120 mm²
Torque: section from 35 to 120 mm² 28 N.m

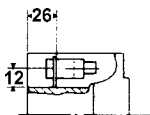

Front with sloped tunnel terminals for cables without lugs
Capacity : min. 35 mm² max. 120 mm²
Torque: sloped extender 14 N.m (M8)
section from 35 to 120 mm² 28 N.m

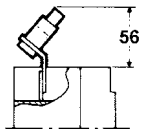

Rear connections for bars or cables with lugs
Bar width max. 25 mm
Torque: rear connection 10 N.m (M6)
bar or cable with lug 7 N.m (M8)

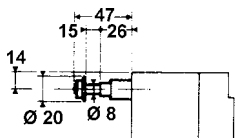

Rear connections for cables without lugs
Capacity : min. 35 mm² max. 120 mm²
Torque :
rear connection 10 N.m (M6)
section from 35 to 120 mm² 28 N.m

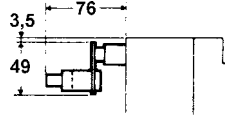

Withdrawable circuit breakers D250

Front for bars or cables with lugs
Bar width max. 25 mm
Torque :
bar or cable with lug 28 N.m (M10)

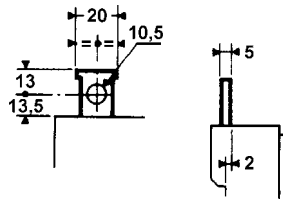

Front with tunnel terminals for cables without lugs
Capacity : min. 35 mm² max. 120 mm²
Torque :
section from 35 to 120 mm² 28 N.m

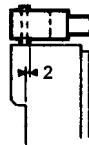

Front with sloped tunnel terminals for cables without lugs
Capacity : min. 35 mm² max. 120 mm²
Torque :
sloped extender 14 N.m (M8)
section from 35 to 120 mm² 28 N.m

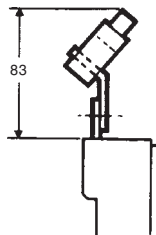

Rear connections for bars or cables with lugs
Bar width max. 25 mm
Torque :
bar or cable with lug 28 N.m (M10)

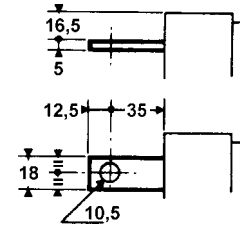

Fixed circuit breakers D400

Front for bars or cables with lugs
Bar width max. 32 mm
Torque :
bar or cable with lug 28 N.m (M10)

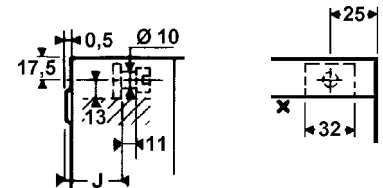

J : 38 mm (upline)
J : 35.5 mm (downline)

Extender with front connections for bars or cables with lugs
Bar width max. 32 mm
Torque :
extender 28 N.m (M10)
bar or cable with lug 28 N.m (M10)

Flat bar mounting

Narrow edge bar mounting

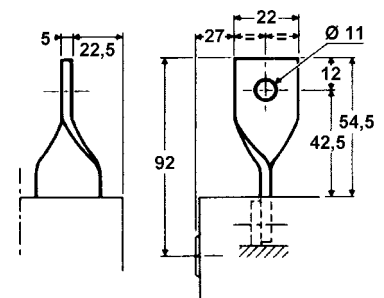



Rear connections plus tunnel connections for cables without lugs
Capacity : min. 95 mm² max. 240 mm²
Torque :
rear connection 36 N.m (M10)
section from 95 to 240 mm² 42 N.m

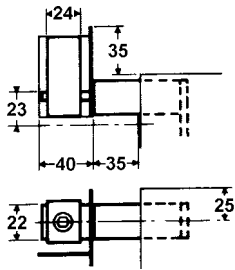

Rear connections for bars or cables with lugs
Bar width max. 32 mm
Torque :
rear connection 36 N.m (M10)
bar or cable with lug 28 N.m (M10)

Flat bar mounting

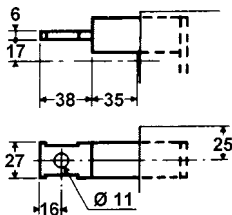

Narrow edge bar mounting

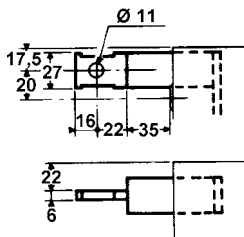

Withdrawable circuit breakers D400

Connection via sections for bars
Bar width max. 25 mm
Torque :
bar 8 N.m (M6)

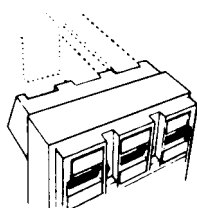
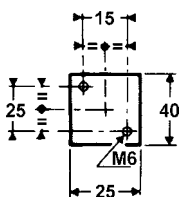
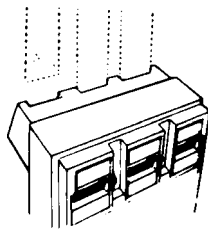

Extender with front connections for bars or cables with lugs
Bar width max. 25 mm
Torque :
extender 8 N.m (M6)
bar or cable with lug 28 N.m (M10)

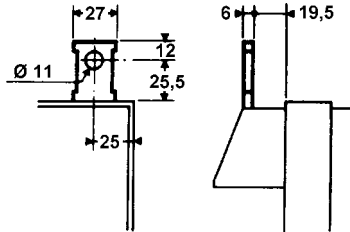

Extender with front connections plus tunnel connections for cables without lugs
Capacity : min. 95 mm² max. 240 mm²
Torque :
extender 8 N.m (M6)
section from 95 to 240 mm² 42 N.m

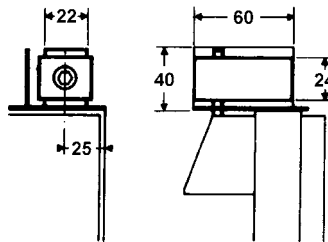

Rear connections for bars or cables with lugs
Bar width max. 25 mm
Torque :
extender 8 N.m (M6)
bar or cable with lug 28 N.m (M10)

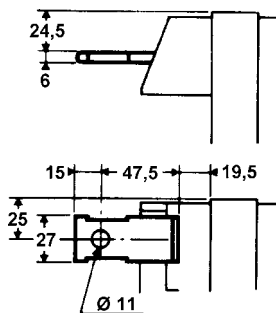

Rear connections plus tunnel connections for cables without lugs
Capacity : min. 95 mm² max. 240 mm²
Torque :
extender 8 N.m (M6)
section from 95 to 240 mm² 42 N.m

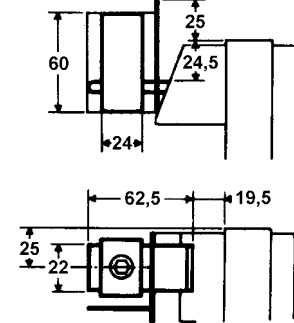

Fixed circuit breakers D630

Front for bars or cables with lugs
Bar width max. 40 mm
Torque :
bar or cable with lug 48 N.m (M12)

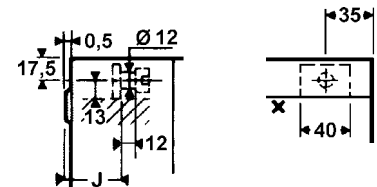

J = 44 mm (upline)
41 mm (downline)

Extender with front connections for bars or cables with lugs
Bar width max. 40 mm
Torque :
extender 8 N.m (M6)
bar or cable with lug 48 N.m (M12)

Flat bar mounting

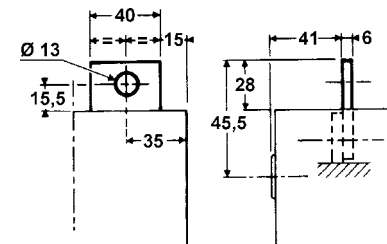

Narrow edge bar mounting

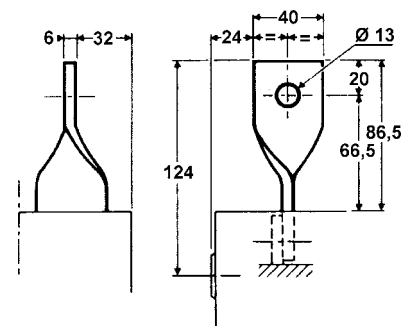

Rear connections plus tunnel connections for cables without lugs
 Ratings 400 and 500 A only
 Capacity : min. 185 mm² max. 300 mm²
 Torque :
 rear connection 55 N.m (M12)
 section from 185 to 300 mm² 9 N.m

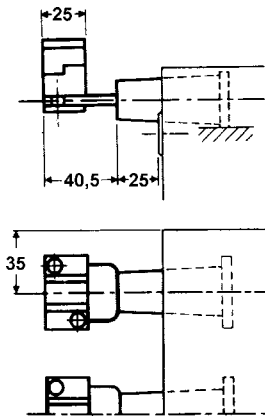

Rear connections for bars or cables with lugs
 Ratings 400 and 500 A only
 Bar width max. 40 mm
 Torque :
 rear connection 55 N.m (M12)
 bar or cable with lug 48 N.m (M12)

Flat bar mounting

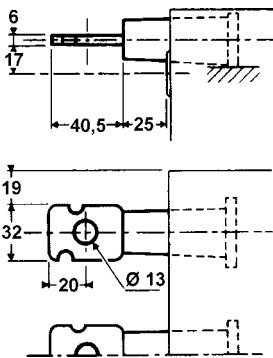

Narrow edge bar mounting

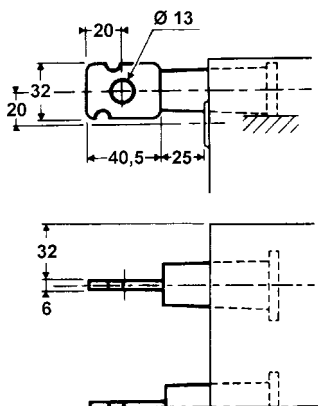

Rear connections for bars or cables with lugs
 Ratings 630 A
 Bar width max. 40 mm
 Torque :
 rear connection 8 N.m (M6)
 bar or cable with lug 48 N.m (M12)

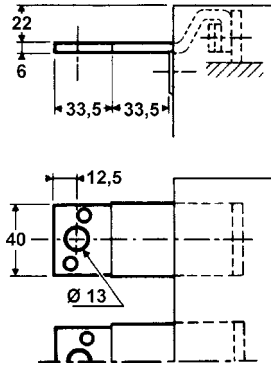

Rear connections plus tunnel connections for cables without lugs
 Ratings 630 A
 Capacity : min. 185 mm² max. 300 mm²
 Torque :
 rear connection 8 N.m (M6)
 section from 185 to 300 mm² 9 N.m

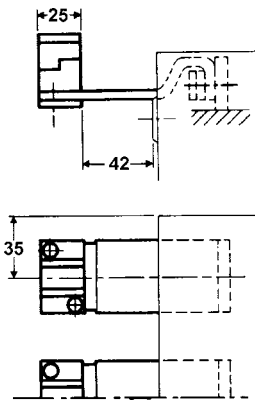

Withdrawable circuit breakers D630

Connection sections for bars
 Bar width max. 40 mm
 Torque :
 bar 8 N.m (M6)

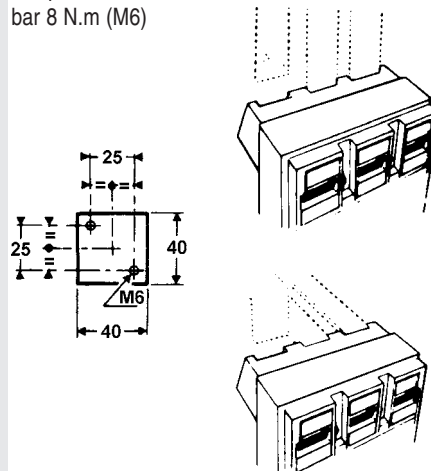

Extender with front connections for bars or cables with lugs
 Bar width max. 40 mm
 Torque :
 extender 8 N.m (M6)
 bar or cable with lug 48 N.m (M12)

Flat bar mounting

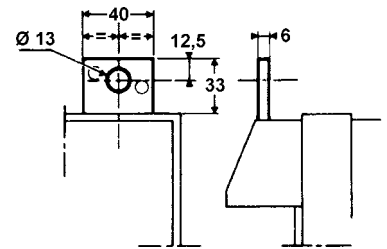

Extender with front connections plus tunnel connections for cables without lugs
 Capacity : min. 185 mm² max. 300 mm²
 Torque :
 extender 8 N.m (M6)
 section from 185 to 300 mm² 9 N.m

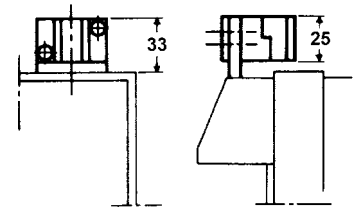

Rear connections for bars or cables with lugs
 Bar width max. 40 mm
 Torque :
 rear connection 8 N.m (M6)
 bar or cable with lug 48 N.m (M12)

Flat bar mounting

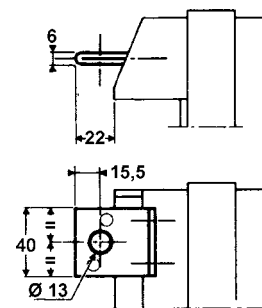

Narrow edge bar mounting

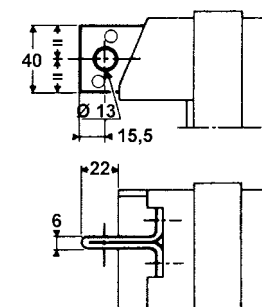



Rear connections plus tunnel connections for cables without lugs
 Capacity : min. 185 mm² max. 300 mm²
 Torque :
 rear connection 8 N.m (M6)
 section from 185 to 300 mm² 9 N.m

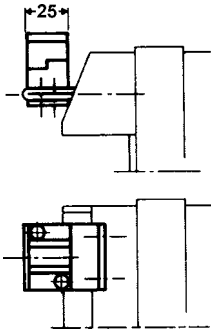

Rear connections for bars or cables with lugs
 Bar width max. 50 mm
 Torque :
 rear connection 8 N.m (M6)
 bar or cable with lug 48 N.m (M12)

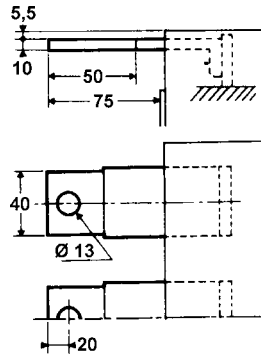

Rear connections for bars or cables with lugs
 Bar width max. 50 mm
 Torque :
 extender 28 N.m (M10)
 bar or cable with lug 48 N.m (M12)

Flat bar mounting

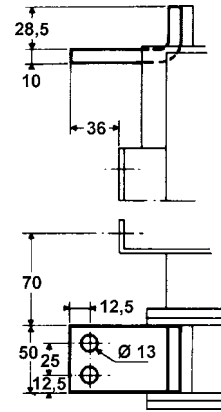

Fixed circuit breakers D800

Front extender for bars or cables with lugs
 Bar width max. 50 mm
 Torque :
 extender 48 N.m (M12)
 bar or cable with lug 48 N.m (M12)

Flat bar mounting

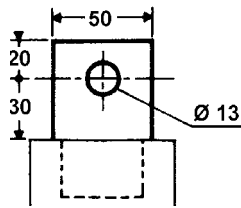

Narrow edge bar mounting

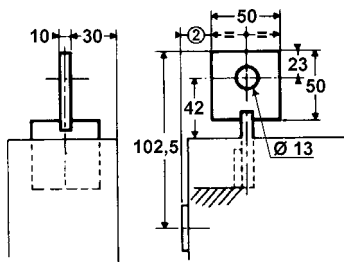

② = 24 mm for rating 630 A
 27 mm for rating 800 A

Withdrawable circuit breakers D800

Front extender for bars or cables with lugs
 Bar width max. 50 mm
 Torque :
 extender 28 N.m (M10)
 bar or cable with lug 48 N.m (M12)

Flat bar mounting (without extender)

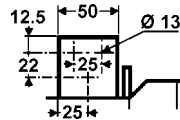

Narrow edge bar mounting

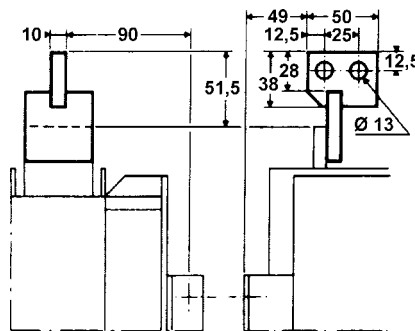

Narrow edge bar mounting

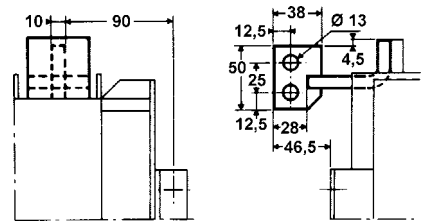

Fixed circuit breakers D1250

Front extender for bars or cables with lugs
 Bar width max. 50 mm
 Torque :
 extender 35 N.m (M10)
 Bar or cable with lug 48 N.m (M12)
 Spreader 48 N.m (M12)

Flat bar mounting

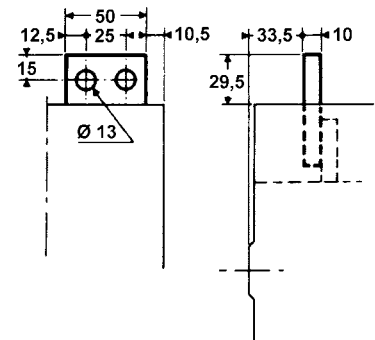

Narrow edge bar mounting

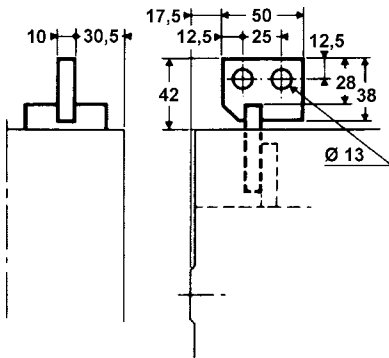

Spreader for connection to cables with lugs

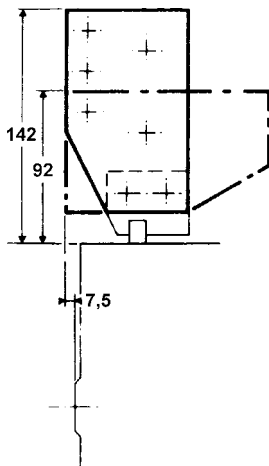

Rear connections for bars or cables with lugs
 Bar width max. 50 mm
 Torque :
 extender 35 N.m (M10)
 bar or cable with lug 48 N.m (M12)
 Spreader 48 N.m (M12)

Flat bar mounting

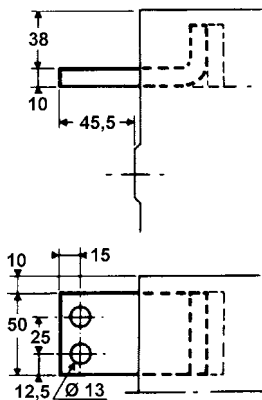

Narrow edge bar mounting

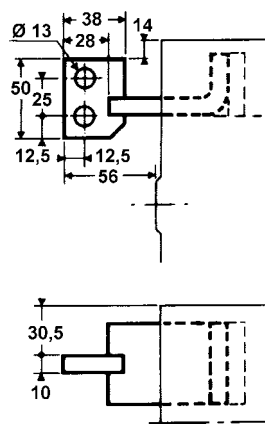

Spreader for connection to cables with lugs

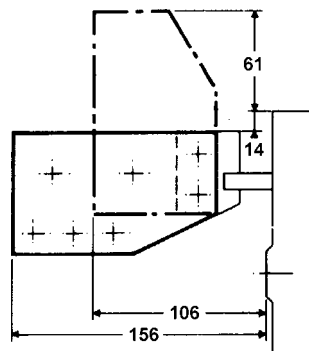

Withdrawable circuit breakers D1250

Front extender for bars or cables with lugs
 Bar width max. 50 mm
 Torque :
 extender 48 N.m (M12)
 bar or cable with lug 48 N.m (M12)
 Spreader 48 N.m (M12)

Narrow edge bar mounting

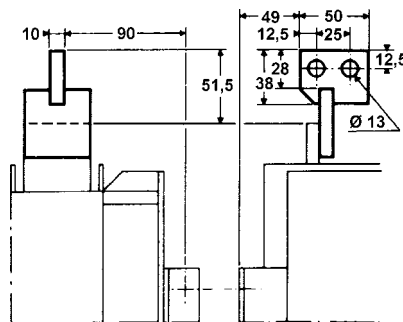

Spreader for connection to cables with lugs

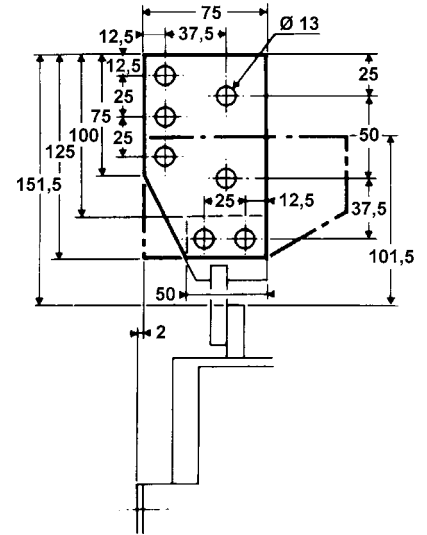

Typical spreader assembly for connection upline or downline from fixed or withdrawable circuit breakers via cables with lugs

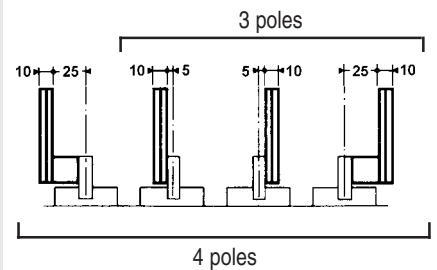

Rear connections for bars or cables with lugs
 Bar width max. 50 mm
 Torque :
 extender 48 N.m (M12)
 bar or cable with lug 48 N.m (M12)
 Spreader 48 N.m (M12)

Flat bar mounting

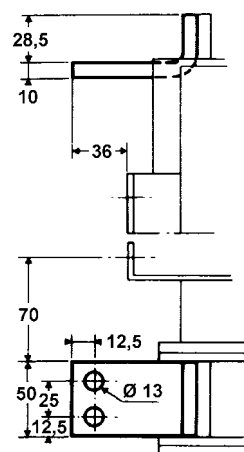



Narrow edge bar mounting

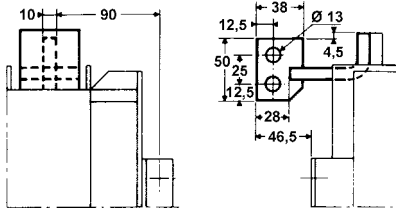

Spreader for connection to cables with lugs

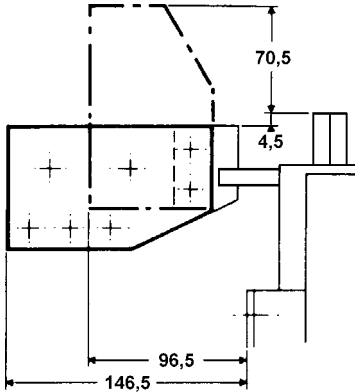

Overall dimensions

MTS detection core

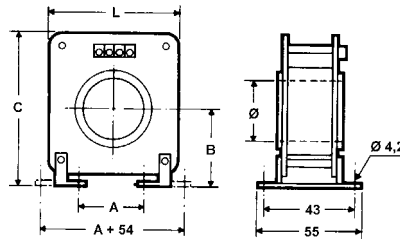

	Cable passage			
	Ø 35	Ø 55	Ø 70	Ø 100
A	35	73	98	138
B	45	64	76	99
C	99	134	156	209
L	82	120	145	185

MTS relay

Recessed mounting

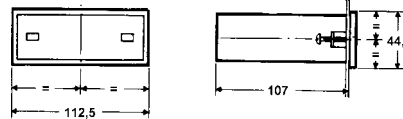

Cut-out plan

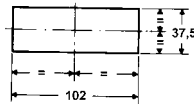

Bottom of housing mounting

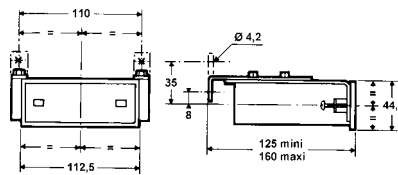

SHR 1100 - SHR 1110

Clipping onto DIN rail

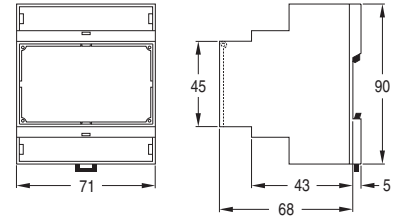

Detection cores

Non-opening CITF

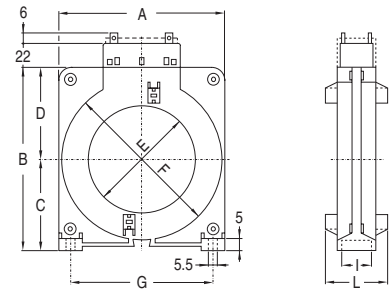

	CITF 35	CITF 80	CITF 110	CITF 140	CITF 210
A	92	125	165	200	290
B	85	132	170	205 ⁵	295
C	42	67	89	103 ⁵	150
D	43	65	84	102	145
EØ	35	80	110	140	210
FØ	74	120	158	194	282
G	75	108	148	177	270
I	23	23	23	23	23
L	56	56	56	56	64
M	yes	yes	yes	yes	no

Opening CITO

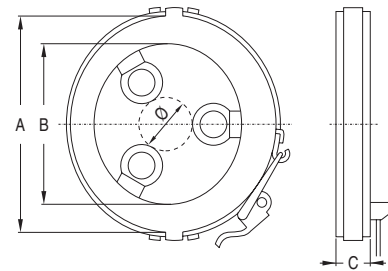

	CITO 65	CITO 104
A	103	145
B	65	104
C	34	44
Ø	26 to 47	68 to 90



Weights(kg)

A
134

	125			160		250	
	2 poles	3 poles	4 poles	3 poles	4 poles	3 poles	4 poles
Fixed circuit breaker front connections	0.680	0.840	1.100	1.800	2.300	2.300	2.700
Earth-leakage circuit breaker, fixed front connections	0.990	1.170	1.460	3.000	3.900	3.900	4.700
Fixed limiter circuit breaker front connections	1.100	1.360	1.780	3.000	3.900	3.800	4.600
Withdrawable circuit breaker front connections	1.050	1.320	1.710	2.870	3.660	3.700	4.400
Withdrawable earth leakage circuit breaker front connections	1.450	1.730	2.180	5.170	6.660	6.700	8.200
Withdrawable limiter circuit breaker front connections	1.580	1.940	2.520	5.170	6.660	6.600	8.100
Withdrawable circuit breaker rear connections	-	-	-	2.990	3.820	3.760	4.480
Withdrawable earth leakage circuit breaker rear connections	-	-	-	5.290	6.820	6.670	8.280
Withdrawable limiter circuit breaker rear connections	-	-	-	5.290	6.820	6.660	8.180
Withdrawable adaptation							
complete unit front connections	0.370	0.480	0.610	1.070	1.360	1.400	1.700
complete unit rear connections	-	-	-	1.190	1.520	1.460	1.780
fixed part front connections	0.320	0.400	0.500	0.800	1.000	1.100	1.300
fixed part rear connections	-	-	-	0.920	1.160	1.160	1.380
connecting plate for earth leakage circuit breaker or limiter	-	-	-	1.100	1.400	1.400	1.800
moving plate	-	-	-	0.270	0.360	0.300	0.400
Earth leakage unit	-	-	-	1.200	1.600	1.600	2.000
Limiter unit	0.420	0.520	0.680	1.200	1.600	1.500	1.900
VE visible isolation circuit breaker							
complete unit	-	-	-	2.420	2.660	2.700	3.000
fixed part	-	-	-	2.150	2.300	2.400	2.600
moving part	-	-	-	0.270	0.360	0.300	0.400
V visible isolation circuit breaker							
complete unit	-	-	-	3.220	3.460	3.450	3.750
fixed part	-	-	-	2.950	3.100	3.150	3.350
moving part	-	-	-	0.270	0.360	0.300	0.400
Auxiliary							
"ON/OFF" display contact							
1 unit	0.025	0.025	0.025	0.040	0.040	0.040	0.040
2 units	0.035	0.035	0.035	0.070	0.070	0.070	0.070
fault display contact	0.025	0.025	0.025	0.040	0.040	0.040	0.040
fault and "ON/OFF" display contact							
1 unit	-	-	-	0.070	0.070	0.070	0.070
2 units	-	-	-	0.100	0.100	0.100	0.100
undervoltage release	0.075	0.075	0.075	0.080	0.080	0.080	0.080
Accessories							
Connections (for 1 pole)	-	-	-	fixo	extr.	fixo	extr.
tunnel terminals	-	-	-	0.050	0.045	0.080	0.075
rear connections							
bars or cables with lugs	0.050	0.050	0.050	0.160	1.000	0.180	0.120
cables without lugs	-	-	0.240	0.180	0.270	0.210	
front connections							
extenders	-	-	-	0.080	0.090	0.100	0.130
bars or cables with lugs							
sloped terminals, cables without lugs	-	-	-	0.110	0.120	0.170	0.200
locking control arm	-	-	-	0.025	0.025	0.400	0.400
multi-pole terminal covers (pair)	0.140	0.140	0.170	0.200	0.300	0.200	0.300
wiring isolation device	0.085	0.085	0.085	0.100	0.100	0.100	0.100
Electrical control	1.260	1.260	1.260	1.300	1.300	1.300	1.300
locking control	-	-	-	0.010	0.010	0.010	0.010
Manual rotary controls							
direct on circuit breaker	0.110	0.110	0.110	0.200	0.200	0.200	0.200
with removable handle	0.220	0.220	0.220	0.400	0.400	0.400	0.400
disengageable	0.480	0.480	0.480	0.500	0.500	0.500	0.500
locking the handle	0.060	0.060	0.060	0.060	0.060	0.060	0.060
auxiliary contact							
1 unit	0.010	0.010	0.010	0.030	0.030	0.030	0.030
2 units	0.025	0.025	0.025	0.050	0.050	0.050	0.050

